



Model Name : EC633-RPS



Model Name : EC633D-RPS

EC633-RPS/ EC633D-RPS

Modular-Designed Embedded System

User's Manual

Copyright

This publication contains information that is protected by copyright. No part of it may be reproduced in any form or by any means or used to make any transformation/adaptation without the prior written permission from the copyright holders.

This publication is provided for informational purposes only. The manufacturer makes no representations or warranties with respect to the contents or use of this manual and specifically disclaims any express or implied warranties of merchantability or fitness for any particular purpose. The user will assume the entire risk of the use or the results of the use of this document. Further, the manufacturer reserves the right to revise this publication and make changes to its contents at any time, without obligation to notify any person or entity of such revisions or changes.

Changes after the publication's first release will be based on the product's revision. The website will always provide the most updated information.

© 2025. All Rights Reserved.

Trademarks

Product names or trademarks appearing in this manual are for identification purpose only and are the properties of the respective owners.

FCC and DOC Statement on Class A

This equipment has been tested and found to comply with the limits for a Class A digital device, pursuant to Part 15 of the FCC rules. These limits are designed to provide reasonable protection against harmful interference when the equipment is operated in a residential installation. This equipment generates, uses and can radiate radio frequency energy and, if not installed and used in accordance with the instruction manual, may cause harmful interference to radio communications. However, there is no guarantee that interference will not occur in a particular installation. If this equipment does cause harmful interference to radio or television reception, which can be determined by turning the equipment off and on, the user is encouraged to try to correct the interference by one or more of the following measures:

- Reorient or relocate the receiving antenna.
- Increase the separation between the equipment and the receiver.
- Connect the equipment into an outlet on a circuit different from that to which the receiver is connected.
- Consult the dealer or an experienced radio TV technician for help.

Notice:

1. The changes or modifications not expressly approved by the party responsible for compliance could void the user's authority to operate the equipment.
2. Shielded interface cables must be used in order to comply with the emission limits.

Table of Contents

Chapter 1 - Introduction	6
Overview - EC633-RPS	6
Front View	6
Rear View	6
Overview - EC633D-RPS	7
Front View	7
Rear View	7
Dimensions	8
EC633-RPS	8
EC633D-RPS	8
Key Features	8
Specifications	9
Chapter 2 - Hardware Installations	12
Removing the Chassis Cover	12
Installing a M.2 Card	13
Installing the Mini PCIe Module	14
Installing a PCIe Expansion Card	15
Inserting a HDD/SDD	16
Installing an Antenna	17
Mounting Options.....	17
Wall Mount	17
EC633-RPS	17
EC633D-RPS	18
Chapter 3 - BIOS Settings	19
Overview	19
Main	20
Advanced	20
CPU Configuration.....	21
Power & Performance	21
Power & Performance ▶ CPU- Power Management Control	22
Power & Performance ▶ GT- Power Management Control	22
PCH-FW Configuration	23
Trusted Computing.....	24
IT8786 Super IO Configuration	24
IT8786 Super IO Configuration ▶ Serial Port 1, 2 Configuration	25
IT8786 Super IO Configuration ▶ Serial Port 3, 4 Configuration	25
IT8786 Super IO Configuration ▶ Serial Port 5, 6 Configuration	26
IT8786 HW Monitor	26
IT8786 HW Monitor ▶ Smart FAN Function	27
IT8786 HW Monitor ▶ Smart FAN Function ▶ CPU_FAN Setting	27
IT8786 HW Monitor ▶ Smart FAN Function ▶ SYS_FAN Setting	27
Serial Port Console Redirection	28
Serial Port Console Redirection ▶ Console Redirection Settings	28
ACPI Settings	29
Network Stack Configuration.....	30
NVMe Configuration.....	30
DFI WDT Configuration.....	31
USB Power Control	31
TIs Auth Configuration	32
Chipset	33

System Agent (SA) Configuration	33
PCH-IO Configuration	34
PCH-IO Configuration ▶ PCI Express Configuration	34
PCH-IO Configuration ▶ SATA Configuration	35
PCH-IO Configuration ▶ HD Audio Configuration	35
Security	36
Secure Boot.....	36
Boot	37
Save & Exit	37
MEBx	38
Updating the BIOS	38
Notice: BIOS SPI ROM.....	38

About this Manual

This manual can be retrieved from the website.

The manual is subject to change and update without notice, and may be based on editions that do not resemble your actual products. Please visit our website or contact our sales representatives for the latest editions.

Warranty

1. Warranty does not cover damages or failures that arises from misuse of the product, inability to use the product, unauthorized replacement or alteration of components and product specifications.
2. The warranty is void if the product has been subjected to physical abuse, improper installation, modification, accidents or unauthorized repair of the product.
3. Unless otherwise instructed in this user's manual, the user may not, under any circumstances, attempt to perform service, adjustments or repairs on the product, whether in or out of warranty. It must be returned to the purchase point, factory or authorized service agency for all such work.
4. We will not be liable for any indirect, special, incidental or consequential damages to the product that has been modified or altered.

About this Package

The package contains the following items. If any of these items are missing or damaged, please contact your dealer or sales representative for assistance.

- 1 EC633-RPS/EC633D-RPS system unit
- 1 M.2 & miniPCIe slot screws set
- 1 Terminal block 4 pole for DC input
- 1 Cable with 4 wire stripped and tinned to mini-DIMM

Note: The items are subject to change in the developing stage. The product and accessories in the package may not come similar to the information listed above. This may differ in accordance with the sales region or models in which it was sold. For more information about the standard package in your region, please contact your dealer or sales representative.

Static Electricity Precautions

It is quite easy to inadvertently damage your PC, system board, components or devices even before installing them in your system unit. Static electrical discharge can damage computer components without causing any signs of physical damage. You must take extra care in handling them to ensure against electrostatic build-up.

1. To prevent electrostatic build-up, leave the system board in its anti-static bag until you are ready to install it.
2. Wear an antistatic wrist strap.
3. Do all preparation work on a static-free surface.
4. Hold the device only by its edges. Be careful not to touch any of the components, contacts or connections.
5. Avoid touching the pins or contacts on all modules and connectors. Hold modules or connectors by their ends.



Important:

Electrostatic discharge (ESD) can damage your processor, disk drive and other components. Perform the upgrade instruction procedures described at an ESD workstation only. If such a station is not available, you can provide some ESD protection by wearing an antistatic wrist strap and attaching it to a metal part of the system chassis. If a wrist strap is unavailable, establish and maintain contact with the system chassis throughout any procedures requiring ESD protection.

Safety Precautions

- Use the correct DC / AC input voltage range.
- Unplug the power cord before removing the system chassis cover for installation or servicing. After installation or servicing, cover the system chassis before plugging in the power cord.
- There is danger of explosion if battery incorrectly replaced.
- Replace only with the same or equivalent specifications of batteries recommend by the manufacturer.
- Dispose of used batteries according to local ordinance.
- Keep this system away from humid environments.
- Make sure the system is placed or mounted correctly and stably to prevent the chance of dropping or falling may cause damage.
- The openings on the system shall not be blocked and shall be kept in distance from

other objects to make sure of proper air ventilation to protect the system from over-heating.

- Dress the cables, especially the power cord, so they will not be stepped on, in contact with high temperature surfaces, or cause any tripping hazards.
- Do not place anything on top of the power cord. Use a power cord that has been approved for use with the system and is compliant with the voltage and current ranges required by the system's electrical specifications.
- If the system is to be unused or stored for a long time, disconnect it from the power source to avoid damage by transient overvoltage.
- If one of the following occurs, consult a service personnel:
 - The power cord or plug is damaged.
 - Liquid has penetrated the system.
 - The system has been exposed to moisture.
 - The system is not working properly.
 - The system is physically damaged.
- The unit uses a three-wire ground cable which is equipped with a third pin to ground the unit and prevent electric shock. Do not defeat the purpose of this pin. If your outlet does not support this kind of plug, contact your electrician to replace the outlet.
- Disconnect the system from the electricity outlet before cleaning. Use a damp cloth for cleaning the surface. Do not use liquid or spray detergents for cleaning.
- Before connecting, make sure that the power supply voltage is correct. The device is connected to a power outlet which should be grounded connection.



The system may burn fingers while running.

Wait for 30 minutes to handle electronic parts after power off.

Chapter 1 - Introduction

► Overview - EC633-RPS

Front View

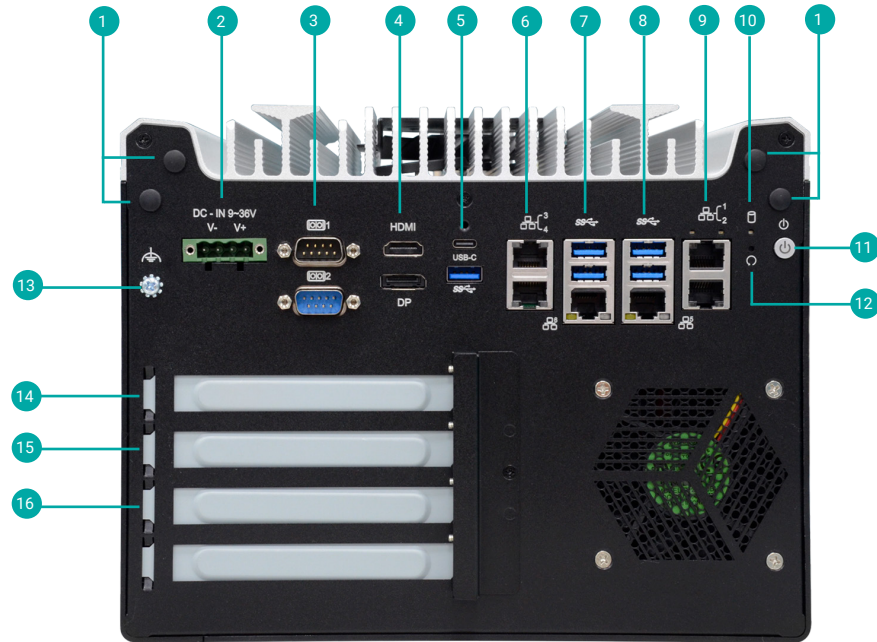

Rear View

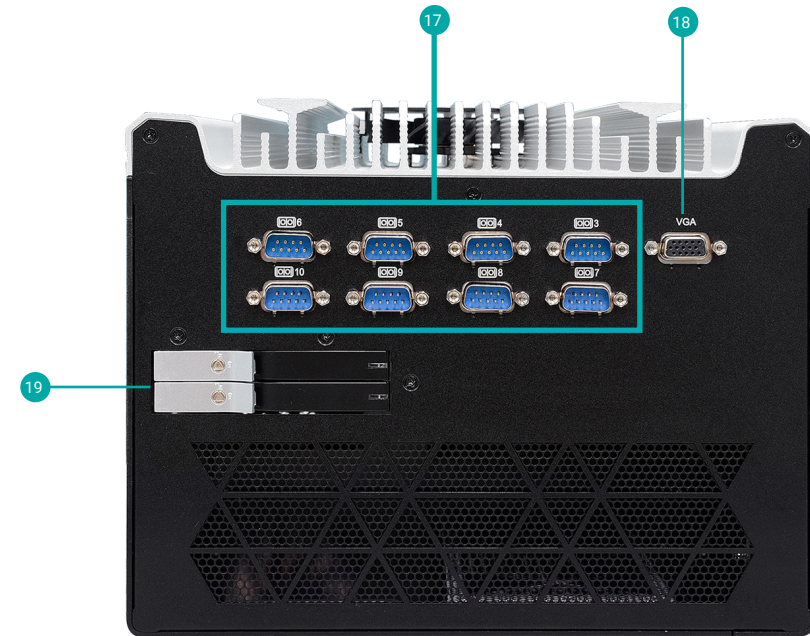

- | | | | | | |
|---|------------------------|----|------------------|----|----------------------------------|
| 1 | Antenna Holes | 7 | ▲USB3.2
▼LAN6 | 13 | Grounding |
| 2 | DC-in | 8 | ▲USB3.2
▼LAN5 | 14 | 1 x PCIe x8 slot
(x4 signal) |
| 3 | ▲COM1
▼COM2 | 9 | ▲LAN1
▼LAN2 | 15 | 1 x PCIe x8 slot
(x8 signal) |
| 4 | ▲HDMI
▼DP | 10 | HDD LED | 16 | 1 x PCIe x16 slot
(x8 signal) |
| 5 | ▲USB Type-C
▼USB3.2 | 11 | Power Button | | |
| 6 | ▲LAN3
▼LAN4 | 12 | Reset Button | | |

- | | |
|----|--------------------|
| 17 | COM3~COM10 |
| 18 | VGA |
| 19 | Storage Driver Bay |

► Overview - EC633D-RPS

Front View

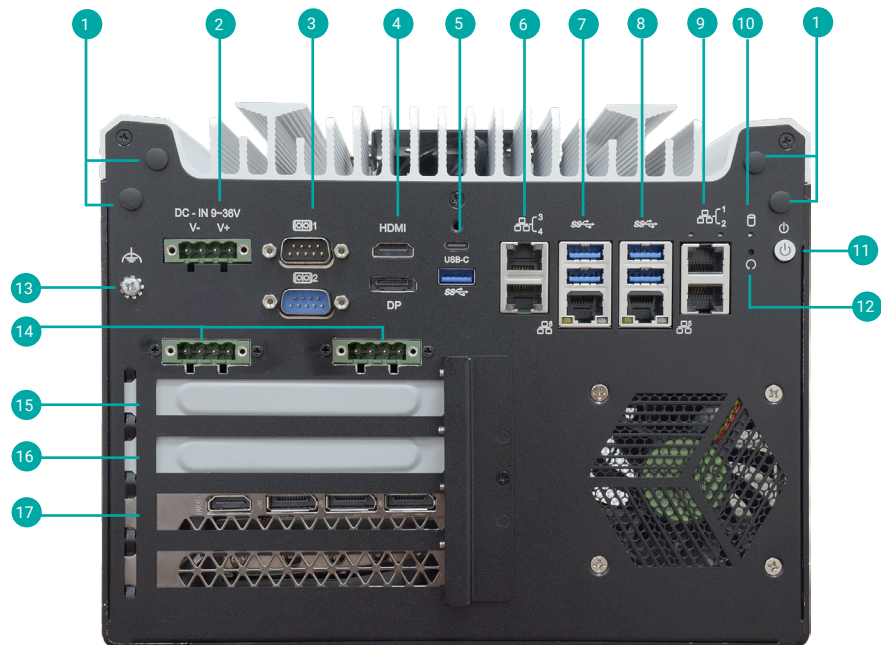

Rear View

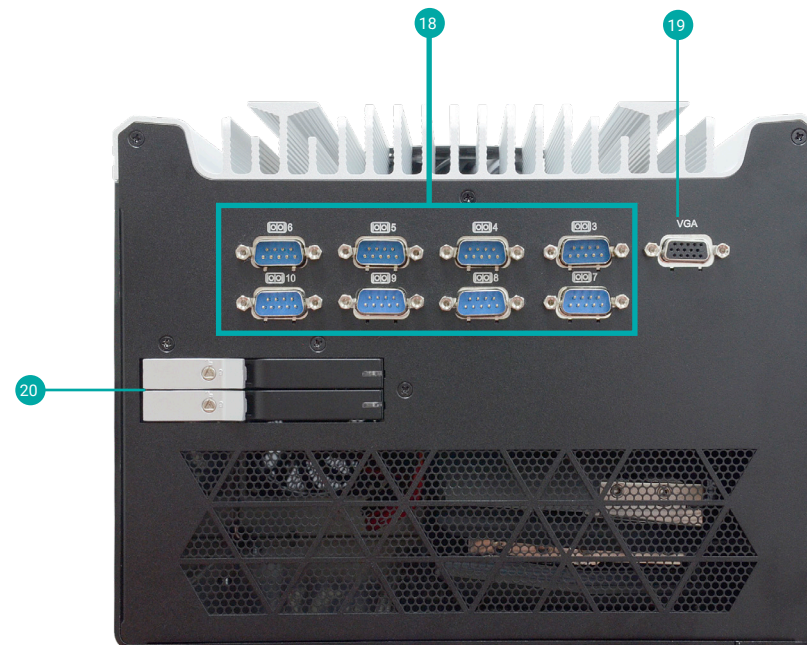

- | | | | | | |
|---|------------------------|----|------------------|----|----------------------------------|
| 1 | Antenna Holes | 7 | ▲USB3.2
▼LAN6 | 13 | Grounding |
| 2 | DC-in | 8 | ▲USB3.2
▼LAN5 | 14 | 12V power input (for GPU card) |
| 3 | ▲COM1
▼COM2 | 9 | ▲LAN1
▼LAN2 | 15 | 1 x PCIe x8 slot
(x4 signal) |
| 4 | ▲HDMI
▼DP | 10 | HDD LED | 16 | 1 x PCIe x8 slot
(x8 signal) |
| 5 | ▲USB Type-C
▼USB3.2 | 11 | Power Button | 17 | 1 x PCIe x16 slot
(x8 signal) |
| 6 | ▲LAN3
▼LAN4 | 12 | Reset Button | | |

- | | |
|----|--------------------|
| 18 | COM3~COM10 |
| 19 | VGA |
| 20 | Storage Driver Bay |

► Dimensions

EC633-RPS

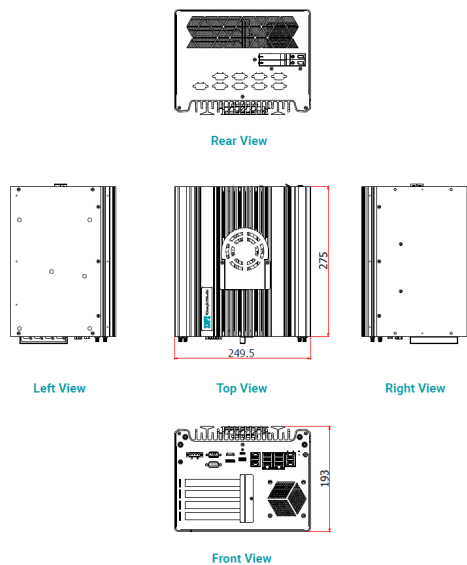

EC633D-RPS

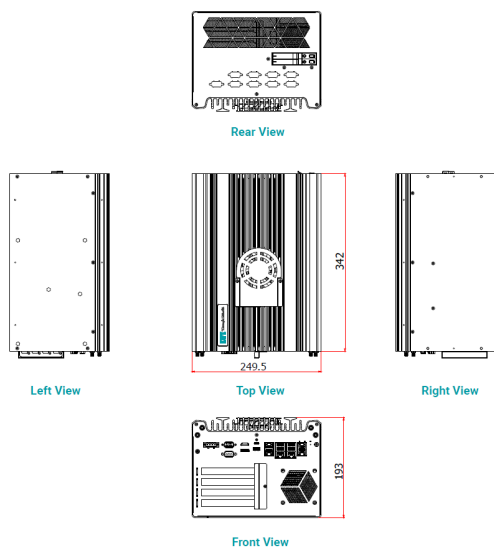

► Key Features

DDR5:

DDR5 SODIMM up to 64GB

Wide-Temperature:

Operating temperature: -20 to 70°C

Support OOB:

DFI OOB module (M.2 3042 A key)

Multiple Expansion:

5 M.2 slots (1 M.2 2230 E key, 2 M.2 2280 M key, 1 M.2 3042/3052 B key, 1 M.2 3042 A key)
1 mini-PCIe slot (full size)

Rich I/O

2 2.5GbE, 4 GbE, 5 USB3.2 Gen2, 1 USB type-C, 1 VGA, 1 HDMI, 1 DP++, 9 com port

Support 5G Communication

Support 5G communication

► Specifications

SYSTEM Processor

14th Generation Intel® LGA 1700 Socket Processors, TDP support up to 65W

Intel® Core™ i9-14900 (24 Cores, 36M Cache, up to 2.0 GHz); 65W
 Intel® Core™ i9-14900T (24 Cores, 36M Cache, up to 1.1 GHz); 35W
 Intel® Core™ i7-14700 (20 Cores, 33M Cache, up to 2.1 GHz); 65W
 Intel® Core™ i7-14700T (20 Cores, 33M Cache, up to 1.3 GHz); 35W
 Intel® Core™ i5-14500 (14 Cores, 24M Cache, up to 2.6 GHz); 65W
 Intel® Core™ i5-14500T (14 Cores, 24M Cache, up to 1.7 GHz); 35W
 Intel® Core™ i5-14400 (10 Cores, 20M Cache, up to 2.5 GHz); 65W
 Intel® Core™ i5-14400T (10 Cores, 20M Cache, up to 1.5 GHz); 35W
 Intel® Core™ i3-14100 (4 Cores, 12M Cache, up to 3.5 GHz); 60W
 Intel® Core™ i3-14100T (4 Cores, 12M Cache, up to 2.7 GHz); 35W

13th Generation Intel® LGA 1700 Socket Processors, TDP support up to 65W

Intel® Core™ i9-13900E (24 Cores, 36M Cache, up to 5.2 GHz); 65W
 Intel® Core™ i9-13900TE (24 Cores, 36M Cache, up to 5.0 GHz); 35W
 Intel® Core™ i7-13700E (16 Cores, 30M Cache, up to 5.1 GHz); 65W
 Intel® Core™ i7-13700TE (16 Cores, 30M Cache, up to 4.8 GHz); 35W
 Intel® Core™ i7-13700T (16 Cores, 30M Cache, up to 4.9 GHz); 35W
 Intel® Core™ i5-13500E (14 Cores, 24M Cache, up to 4.6 GHz); 65W
 Intel® Core™ i5-13500TE (14 Cores, 24M Cache, up to 4.5 GHz); 35W
 Intel® Core™ i5-13500T (14 Cores, 24M Cache, up to 4.6 GHz); 35W
 Intel® Core™ i5-13400E (10 Cores, 20M Cache, up to 4.6 GHz); 65W
 Intel® Core™ i3-13100E (4 Cores, 12M Cache, up to 3.3 GHz); 60W
 Intel® Core™ i3-13100TE (4 Cores, 12M Cache, up to 4.1 GHz); 35W
 Intel® Core™ i3-13100T (4 Cores, 12M Cache, up to 4.2 GHz); 35W

12th Generation Intel® LGA 1700 Socket Processors, TDP support up to 65W

Intel® Core™ i9-12900E (16 Cores, 30M Cache, up to 5.0 GHz); 65W
 Intel® Core™ i9-12900TE (16 Cores, 30M Cache, up to 4.8 GHz); 35W
 Intel® Core™ i7-12700E (12 Cores, 25M Cache, up to 4.8 GHz); 65W
 Intel® Core™ i7-12700TE (12 Cores, 25M Cache, up to 4.6 GHz); 35W
 Intel® Core™ i5-12500E (6 Cores, 18M Cache, up to 4.5 GHz); 65W
 Intel® Core™ i5-12500TE (6 Cores, 18M Cache, up to 4.3 GHz); 35W
 Intel® Core™ i3-12100E (4 Cores, 12M Cache, up to 4.2 GHz); 60W
 Intel® Core™ i3-12100TE (4 Cores, 12M Cache, up to 4.0 GHz); 35W
 Intel® Pentium® G7400E (2 Cores, 6M Cache, 3.6 GHz); 46W
 Intel® Pentium® G7400TE (2 Cores, 6M Cache, 3.0 GHz); 35W
 Intel® Celeron® G6900E (2 Cores, 4M Cache, 3.0 GHz); 46W
 Intel® Celeron® G6900TE (2 Cores, 4M Cache, 2.4 GHz); 35W

Chipset Intel® R680E Chipset

Memory 2x 262-pin SODIMM up to 64GB
 Dual Channel DDR5 4800MHz

BIOS AMI SPI 256Mbit

GRAPHICS	Controller	Intel® HD Gen 9 Graphics
	Feature	OpenGL 4.5, DirectX 12, OpenCL 2.1 HW Decode: AVC/H.264, MPEG2, VC1/WMV9, JPEG/MJPEG, HEVC/H265, VP8, VP9 HW Encode: MPEG2, AVC/H264, JPEG, HEVC/H265, VP8, VP9
	Display	1 x VGA VGA: resolution up to 1920x1200 @ 60Hz 1 x HDMI HDMI: resolution up to 4096x2160 @ 30Hz 1 x DP++ DP++: resolution up to 4096x2304 @ 60Hz
STORAGE	Internal	2 x M.2 2280 M key support RAID 0/1
	External	2 x 2.5" SATA 3.0 driver bay (Rear side) support RAID 0/1
EXPANSION	Interface	1 M.2 2280 M key (SATA/PCIe x4) 1 M.2 2280 M key (PCIe x4) 1 M.2 3042/3052 B key (SATA/PCIex1/USB3, w/ Nano SIM slot) 1 M.2 2230 E key (PCIe x1/ USB2.0) 1 M.2 3042 A key(for support DFI OOB module) 1 miniPCIe full size (PCIe x1/ USB2.0, w/ Nano SIM slot) 1 PCIe x8 (PCIe x16 slot) 1 PCIe x8 (PCIe x8 slot) 1 PCIe x4 (PCIe x8 slot)
ETHERNET	Controller	2 x Intel® I226IT (10/100/1000/2500Mbps) 1 x Intel® I219LM (10/100/1000Mbps) 3 x Intel® I210IT (10/100/1000Mbps)
LED	Indicators	1 x Status LED 1 x HDD LED
FRONT I/O	Ethernet	2 x 2.5 GbE (RJ-45) 4 x GbE (RJ-45), optional 2 x GbE & 2 x PoE
	Serial	2 x RS232/422/485 (DB-9, selectable by BIOS, COM1 can select serial port or DIO by jumper setting)
	USB	5 x USB 3.2 (Gen2x1) 1 x USB Type-C (Alt. mode)
	Display	1 x HDMI 1 x DP++
	DIO	8 bit (DB-9, share with COM1)
	Buttons	1 x Power button 1 x Reset button
	Antenna	4 x Antenna holes

REAR I/O	Serial	8 x RS232 (DB-9)
	Display	1 x VGA
	SIM	2 x Nano SIM slots (internal)
WATCHDOG TIMER	Output & Interval	System Reset, Programmable via Software from 1 to 255 Seconds
SECURITY	TPM	TPM 2.0
POWER	Type	Wide range 9~36V
	Connector	4-pole terminal block
OS SUPPORT	Microsoft	Windows 10 IoT Enterprise 2021 LTSC Windows 11
	Linux	Linux (available upon request)
ENVIRONMENT	Operating Temperature	TDP 35W CPU: -20 to 70°C (wide temperature M.2 SSD storage & airstream 0.7m/sec) TDP 65W CPU: -20 to 50°C (wide temperature M.2 SSD storage & airstream 0.7m/sec)
	Storage Temperature	-20 to 85°C
	Relative Humidity	5 to 95% RH (non-condensing)
MECHANISM	Construction	Metal + Aluminum
	Mounting	Wall mount
	Dimensions (W x H x D)	ECC633-RPS : 249.5 x 193 x 275mm ECC633D-RPS : 249.5 x 193 x 342mm
	Weight	4.5 kg
STANDARDS AND CERTIFICATIONS	Shock	Half sine wave 3G, 11ms, 3 shock per axis
	Vibration	IEC68-2-64
	Certification	CE, FCC Class A



Note:

For more information about OOB setup, please visit DFI website at :
<https://pages.dfi.com/oob-solutions#M2A-OOB>

Chapter 2 - Hardware Installations

► Removing the Chassis Cover

Please observe the following guidelines and follow the instructions to open the system.

1. Make sure the system and all other peripheral devices connected to it have been powered off.
2. Disconnect all power cords and cables.

Step 1:

The 8 screws of the system are used to secure the cover to the chassis. Remove the screws and put them in a safe place for later use.



Step 2:

Slide the cover backwards as shown in the image to open the system.

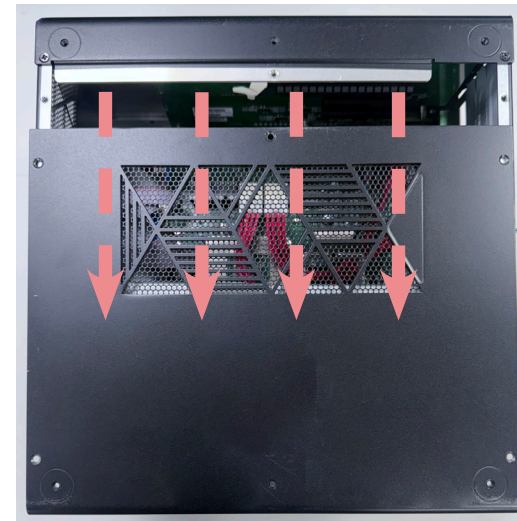

Step 3:

The boards can be easily accessed after the chassis cover is removed.



► **Installing a M.2 Card**

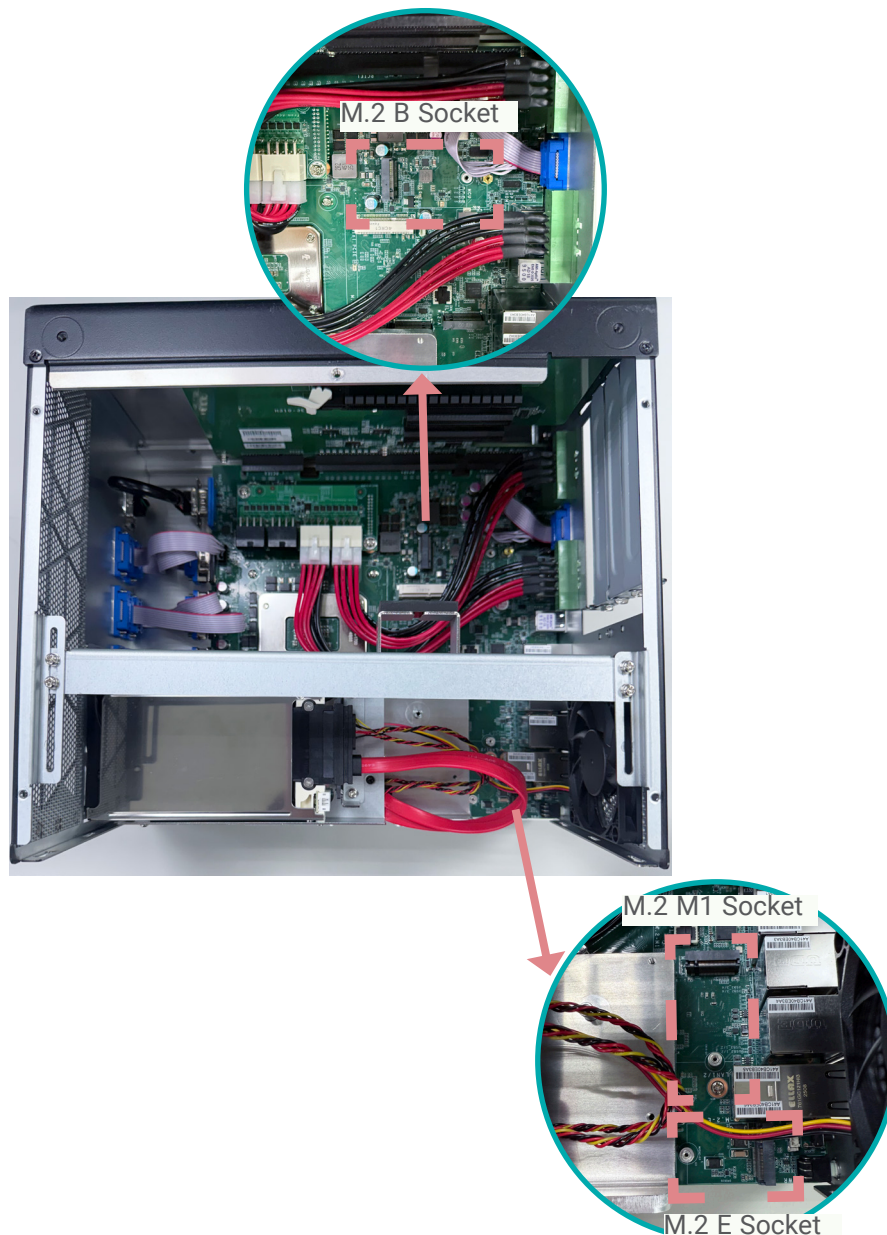

Please follow the steps below to install the card into the socket.

Step 1:

Insert the card into the socket at an angle while making sure the notch and key are perfectly aligned.

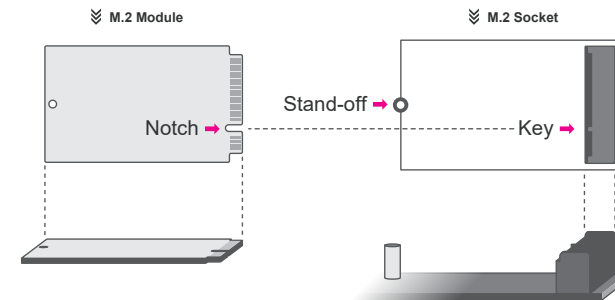

Step 2:

Press the end of the card far from the socket down until against the stand-off.

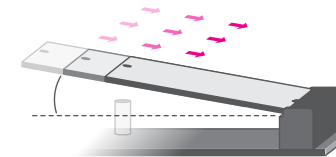

Step 3:

Screw tight the card onto the stand-off with a screw driver and a stand-off screw until the gap between the card and the stand-off closes up. The card should be lying parallel to the board when it's correctly mounted.

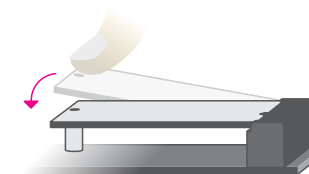

► Installing the Mini PCIe Module

Before installing the Mini PCIe module into the Mini PCIe socket, please make sure that the following safety cautions are well-attended.

1. Make sure the PC and all other peripheral devices connected to it has been powered down.
2. Disconnect all power cords and cables.
3. Locate the Mini PCIe socket on the system board.
4. Make sure the notch on card is aligned to the key on the socket.

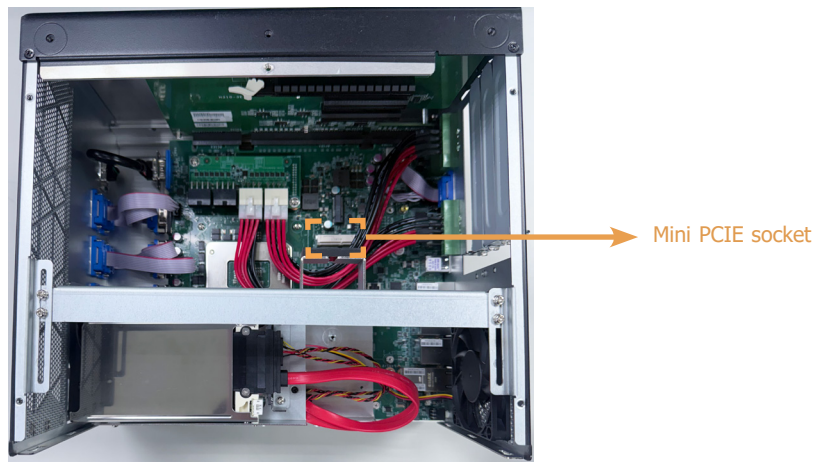

Please follow the steps below to install the Mini PCIe module into the socket.

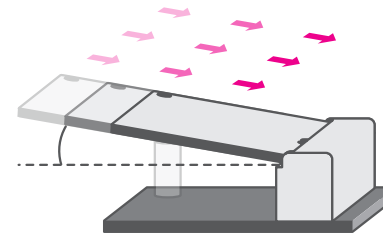

Step 1:

Insert the card into the socket at an angle while making sure the notch and key are perfectly aligned.

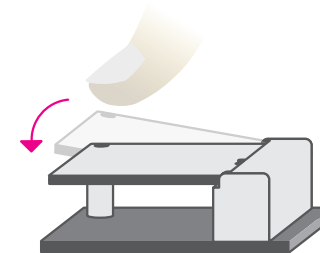

Step 2:

Press the end of the card far from the socket down until against the stand-off.

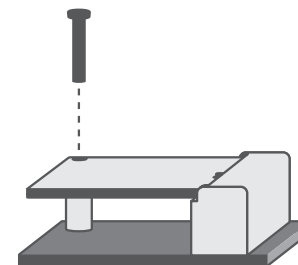

Step 3:

Screw tight the card onto the stand-off with a screw driver and a stand-off screw until the gap between the card and the stand-off closes up. The card should be lying parallel to the board when it's correctly mounted.

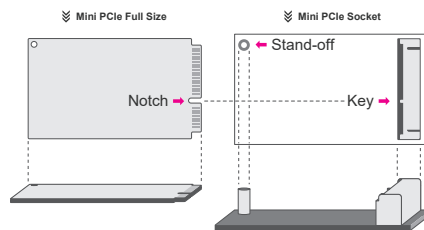

► Installing a PCIe Expansion Card

Please observe the following guidelines and follow the instructions to open the system.

1. Make sure the system and all other peripheral devices connected to it have been powered off.
2. Disconnect all power cords and cables.

Step 1:

PCI and PCIe slots on the system are used to install expansion cards. To install an expansion card, please first remove the screw of the bracket and then remove the screws to disassemble the slot plates.

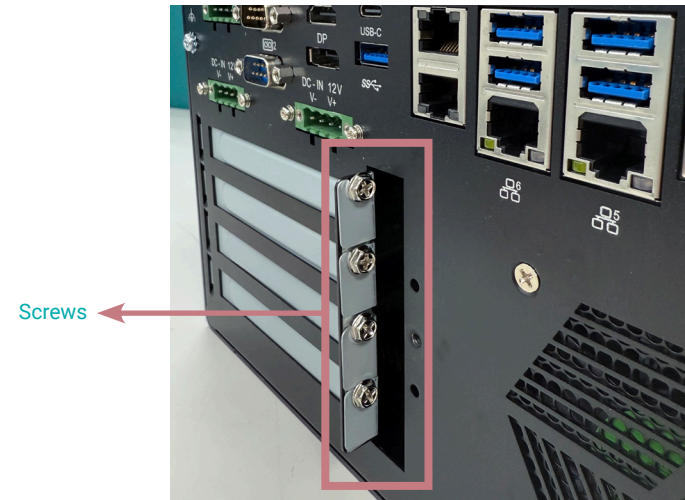
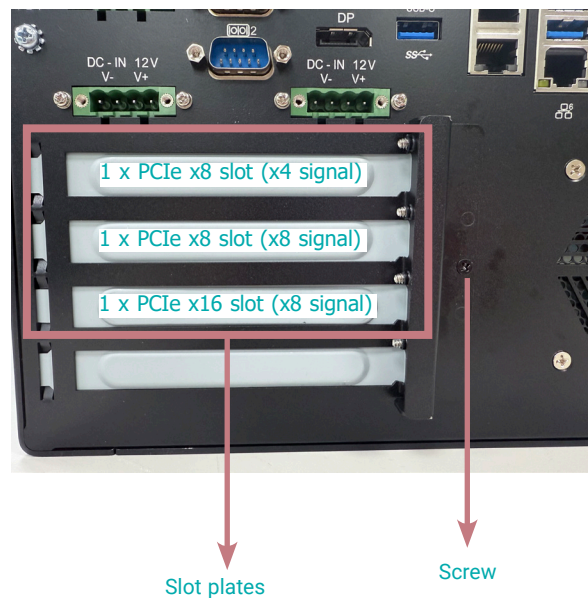

Step 2:

To install an expansion card into the slot, align a card above the slot then press it down firmly until it is completely seated in the slot. The retaining clip of the slot will automatically hold the graphics card in place.



Step 3:

Make sure the power connector is connected to the both motherboard and an expansion card. Reassemble a slot plate and lock the bracket with a screw.

► Inserting a HDD/SDD

Before inserting a HDD/SDD, please turn off the system first.
Use the following procedure to install a SATA HDD or SSD to the system:

Step 1:

The 2.5" HDD/SDD slots on the rear side of the system.
Find the keyslot. Insert the key included in box to unlock it.



Step 2:

Pull the silver latch to open the slot.



Step 3:

Slide the drive into the slot until the drive is fully seated.
Close the drive latch to lock the drive in place.



Important:

Excessive force may damage its mechanical parts.
If the HDD/SSD is inserted backward into the slot, forcing the device
may damage the slot.

► **Installing an Antenna**

Before installing the antenna, please make sure that the following safety cautions are wellattended.

1. Make sure the PC and all other peripheral devices connected to it has been powered down.
2. Disconnect all power cords and cables.

Step 1:

There are antenna holes reserved on the front side of the system and covered by rubber plugs. Please remove the plug prior to installing an antenna.



Step 2:

Connect the internal cable to the board's antenna connector, screw the antenna connector through the antenna hole with washers and nuts, and screw on the antenna as illustrated below.

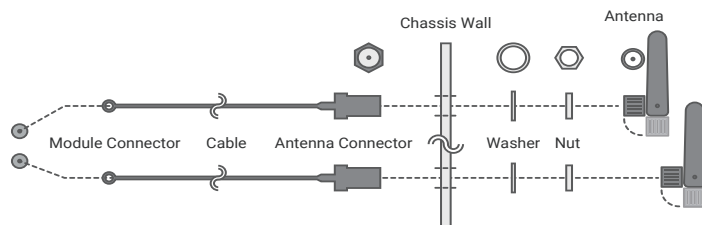

► **Mounting Options**

Wall Mount

The wall mount kit containing two mounting brackets can be attached to the bottom of the system for mounting onto desired locations, such as walls, stands, or shelves. Locate the mounting holes on the bottom of the system as shown in the photo. Screw on the two brackets onto the system tightly as illustrated below.

EC633-RPS

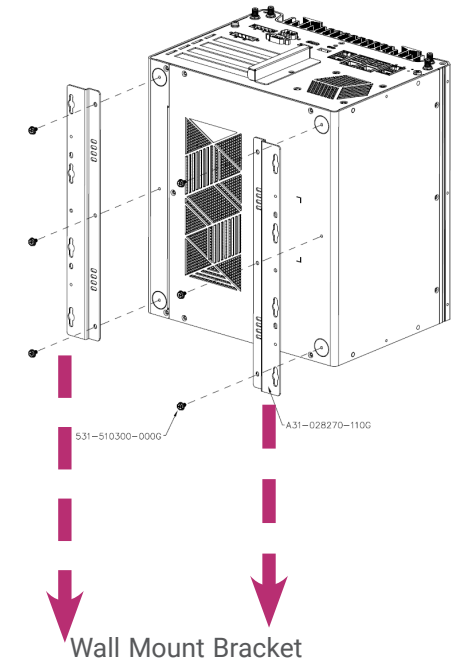
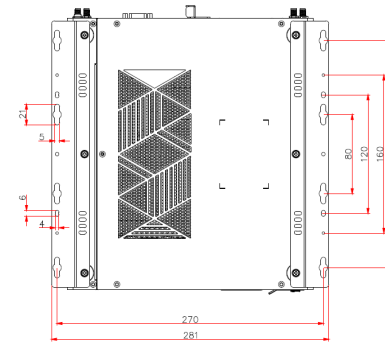

EC633D-RPS

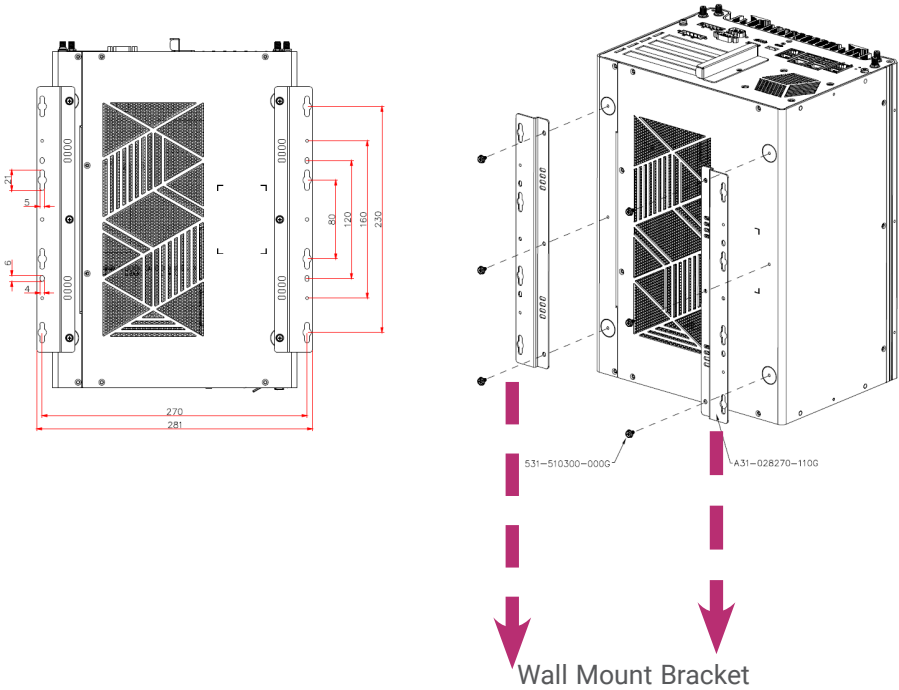

Chapter 3 - BIOS Settings

► Overview

The BIOS is a program that takes care of the basic level of communication between the CPU and peripherals. It contains codes for various advanced features found in this system board.

The BIOS allows you to configure the system and save the configuration in a battery-backed CMOS so that the data retains even when the power is off. In general, the information stored in the CMOS RAM of the EEPROM will stay unchanged unless a configuration change has been made such as a hard drive replaced or a device added.

It is possible that the CMOS battery will fail causing CMOS data loss. If this happens, you need to install a new CMOS battery and reconfigure the BIOS settings.



Note:

The BIOS is constantly updated to improve the performance of the system board; therefore the BIOS screens in this chapter may not appear the same as the actual one. These screens are for reference purpose only.

Default Configuration

Most of the configuration settings are either predefined according to the Load Optimal Defaults settings which are stored in the BIOS or are automatically detected and configured without requiring any actions. There are a few settings that you may need to change depending on your system configuration.

Entering the BIOS Setup Utility

The BIOS Setup Utility can only be operated from the keyboard and all commands are keyboard commands. The commands are available at the right side of each setup screen.

The BIOS Setup Utility does not require an operating system to run. After you power up the system, the BIOS message appears on the screen and the memory count begins. After the memory test, the message "Press DEL to run setup" will appear on the screen. If the message disappears before you respond, restart the system or press the "Reset" button. You may also restart the system by pressing the <Ctrl> <Alt> and keys simultaneously.

Legends

Keys	Function
Right / Left arrow	Move the highlight left or right to select a menu
Up / Down arrow	Move the highlight up or down between submenus or fields
<Enter>	Enter the highlighted submenu
+ (plus key)/F6	Scroll forward through the values or options of the highlighted field
- (minus key)/F5	Scroll backward through the values or options of the highlighted field
<F1>	Display general help
<F2>	Display previous values
<F9>	Optimized defaults
<F10>	Save and Exit
<Esc>	Return to previous menu

Scroll Bar

When a scroll bar appears to the right of the setup screen, it indicates that there are more available fields not shown on the screen. Use the up and down arrow keys to scroll through all the available fields.

Submenu

When "►" appears on the left of a particular field, it indicates that a submenu which contains additional options are available for that field. To display the submenu, move the highlight to that field and press <Enter>.

► Main

The Main menu is the first screen that you will see when you enter the BIOS Setup Utility.

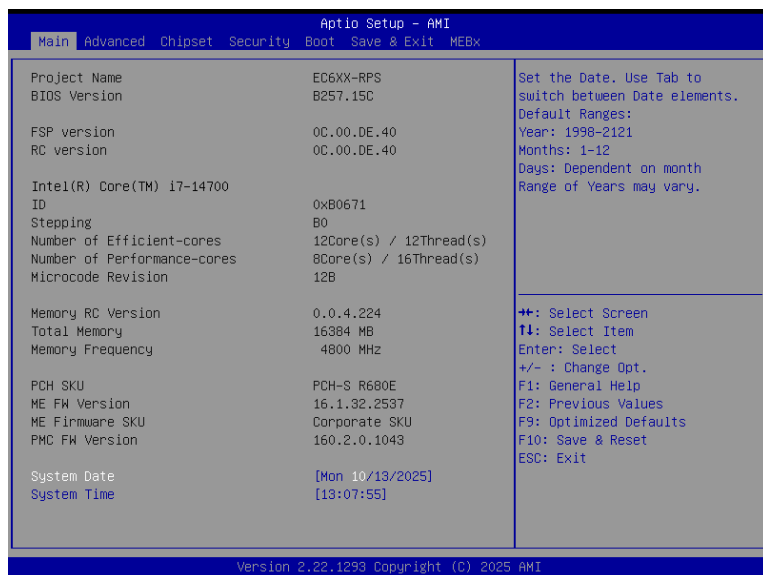

System Date

The date format is <month>, <date>, <year>. Press "Tab" to switch to the next field and press "-" or "+" to modify the value.

System Time

The time format is <hour>, <minute>, <second>. The time is based on the 24-hour military-time clock. For example, 1 p.m. is 13:00:00. Hour displays hours from 00 to 23. Minute displays minutes from 00 to 59. Second displays seconds from 00 to 59.

► Advanced

The Advanced menu allows you to configure your system for basic operation. Some entries are defaults required by the system board, while others, if enabled, will improve the performance of your system or let you set some features according to your preference.



Important:
Setting incorrect field values may cause the system to malfunction.

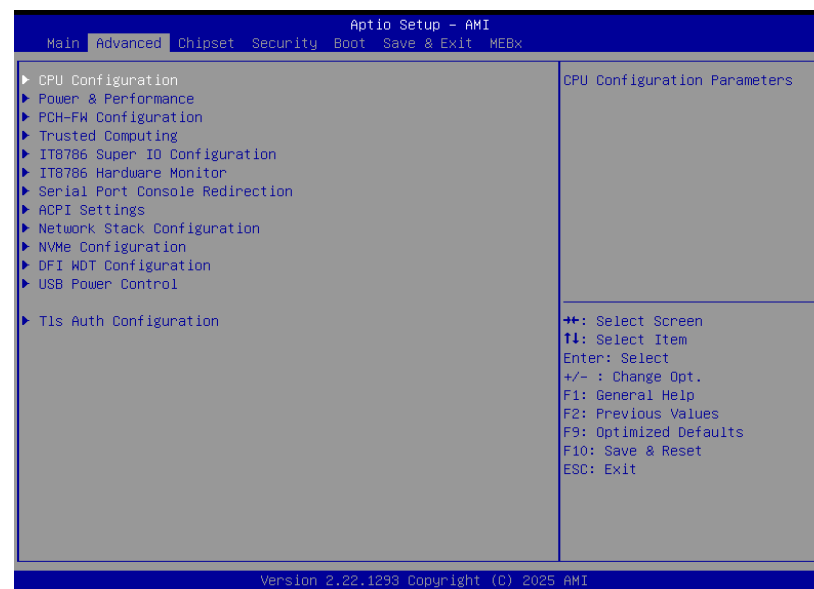

▶ Advanced

CPU Configuration

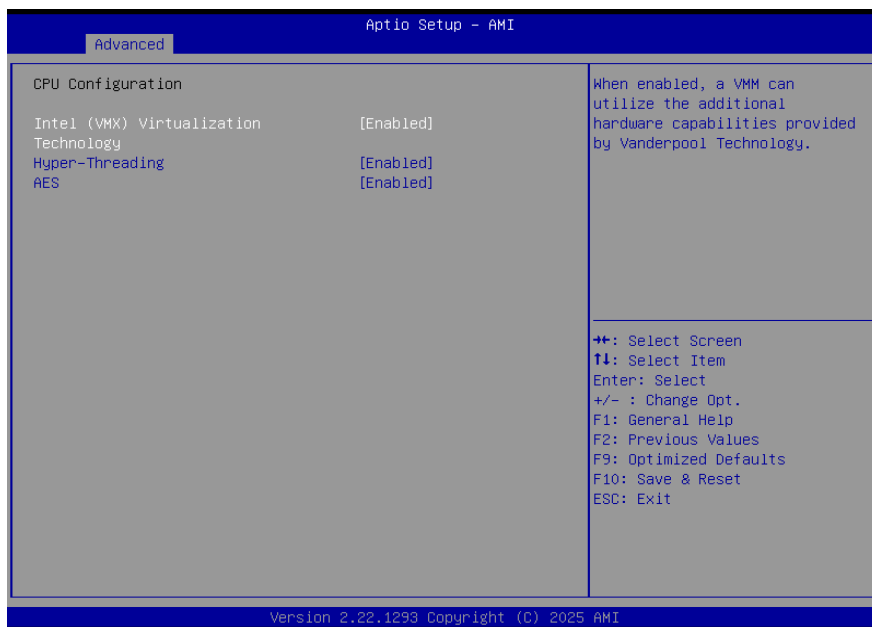

Intel (VMX) Virtualization Technology

When this field is set to Enabled, the VMM can utilize the additional hardware capabilities provided by Vanderpool Technology.

Hyper-threading

Enables this field for Windows XP and Linux which are optimized for Hyper-Threading technology. Select disabled for other OSes not optimized for Hyper-Threading technology. When disabled, only one thread per enabled core is enabled.

AES

Enable / Disable AES (Advanced Encryption Standard)

▶ Advanced

Power & Performance



▶ Advanced

Power & Performance ▶ CPU- Power Management Control



Turbo Mode

Enable/Disable processor Turbo Mode (requires EMTTM enabled too). AUTO means enabled.

Configure Turbo Options

Configure Turbo Options.

C states

Enable or disable CPU Power Management. It allows CPU to enter "C states" when it's idle and nothing is executing.

▶ Advanced

Power & Performance ▶ GT- Power Management Control

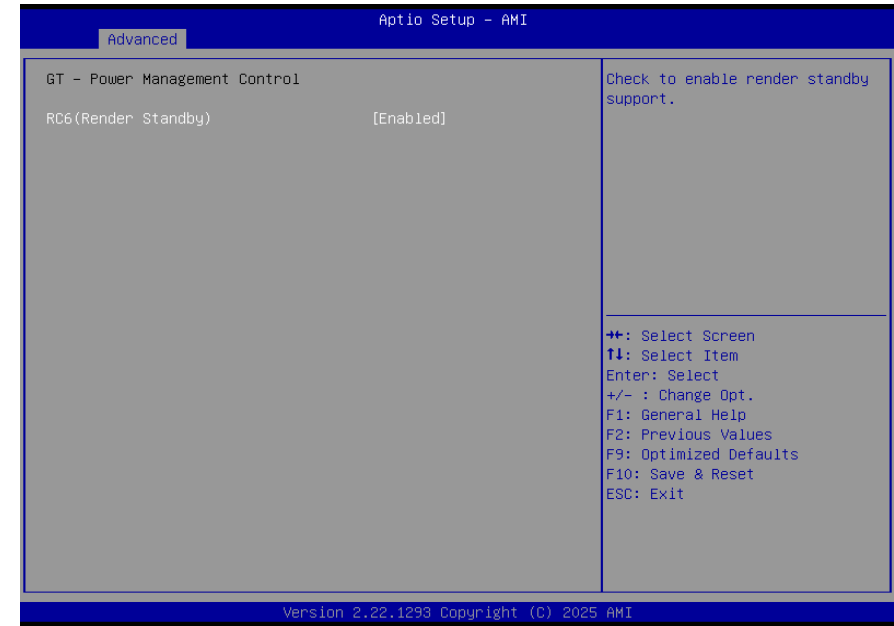

RC6 (Render Standby)

Check to enable render standby support.

▶ Advanced

PCH-FW Configuration

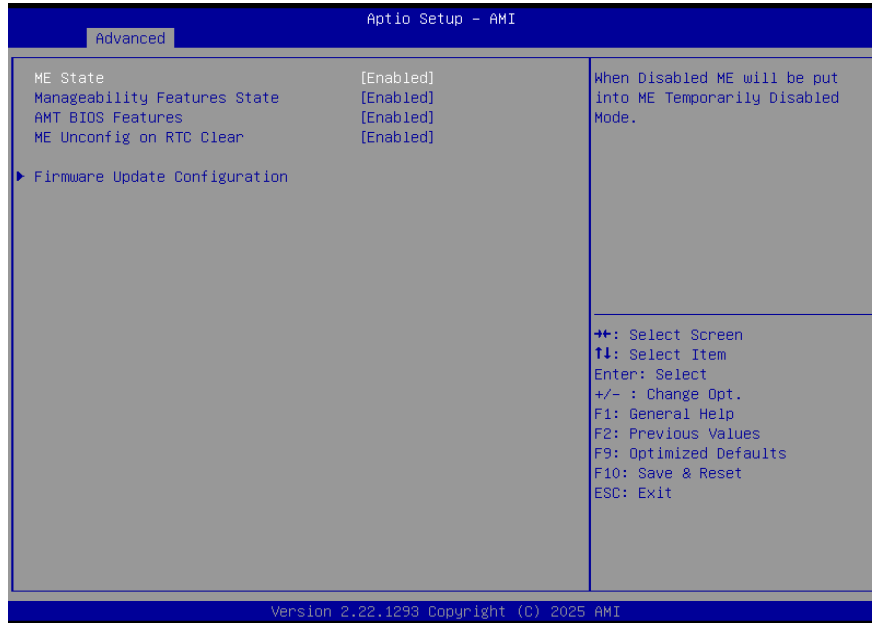

ME State

When this field is set to Disabled, ME will be put into ME Temporarily Disabled Mode.

Manageability Features State

Enable or disable Intel(R) Manageability features. This option disables/enables Manageability Features support in FW. To disable, support platform must be in an unprovisioned state first.

AMT BIOS Features

When disabled, AMT BIOS features are no longer supported and user is no longer able to access MEBx Setup. This option does not disable manageability features in FW.

ME Unconfig on RTC Clear

When disabled, ME will not be unconfigured on RTC Clear.

Firmware Update Configuration

Configure Management Engine Technology Parameters.



Note:
The sub-menus are detailed in following sections.

▶ Advanced

Trusted Computing

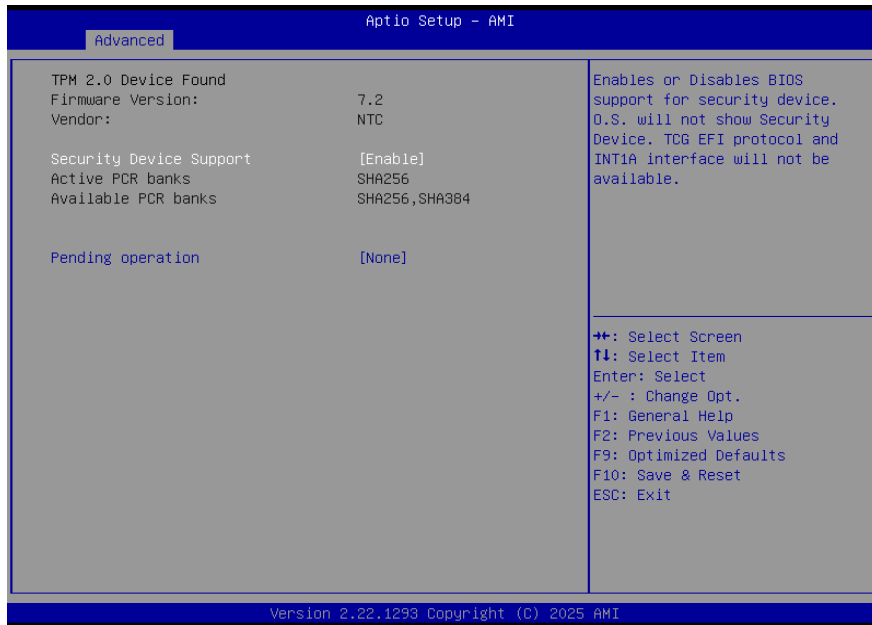

Security Device Support

This field is used to enable or disable BIOS support for the security device such as an TPM 2.0 to achieve hardware-level security via cryptographic keys.

Pending operation

To clear the existing TPM encryption, select "TPM Clear" and restart the system. This field is not available when "Security Device Support" is disabled.

▶ Advanced

IT8786 Super IO Configuration

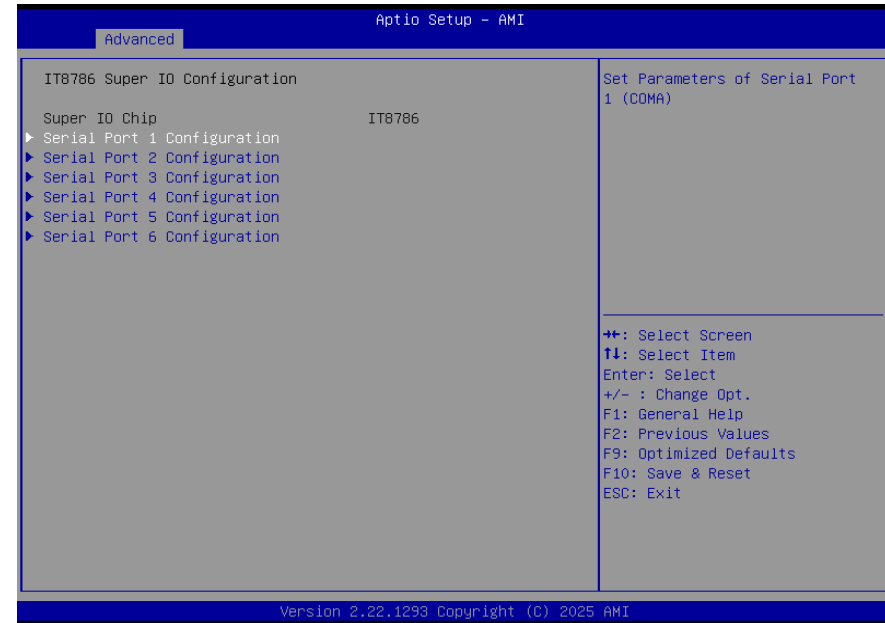

▶ Advanced

IT8786 Super IO Configuration ▶ Serial Port 1, 2 Configuration

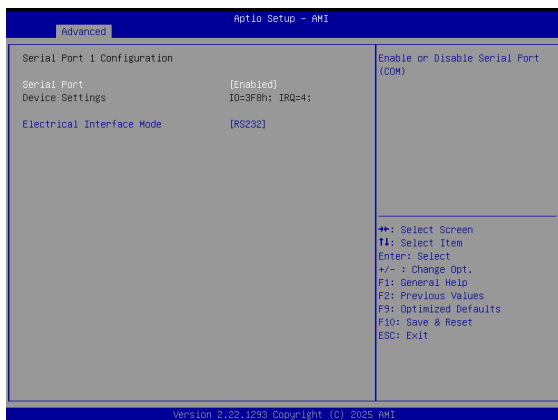

▶ Advanced

IT8786 Super IO Configuration ▶ Serial Port 3, 4 Configuration

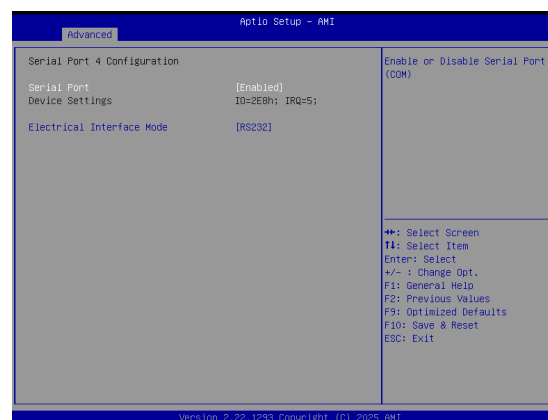
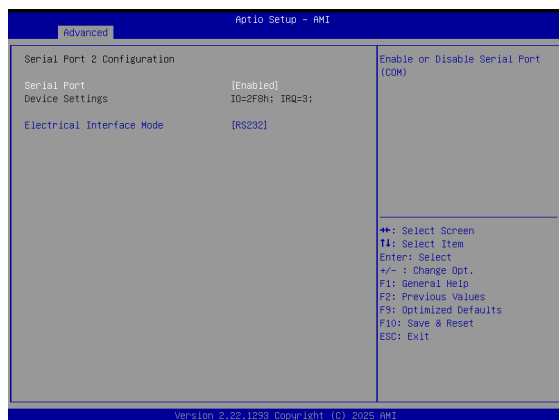
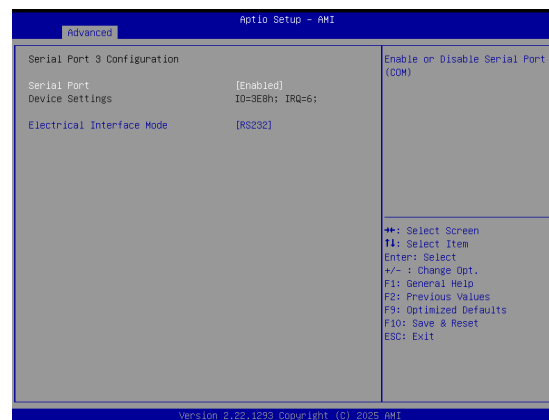

Serial Port

Enable or disable serial port.

Serial Port

Enable or disable serial port.

▶ Advanced

IT8786 Super IO Configuration ▶ Serial Port 5, 6 Configuration

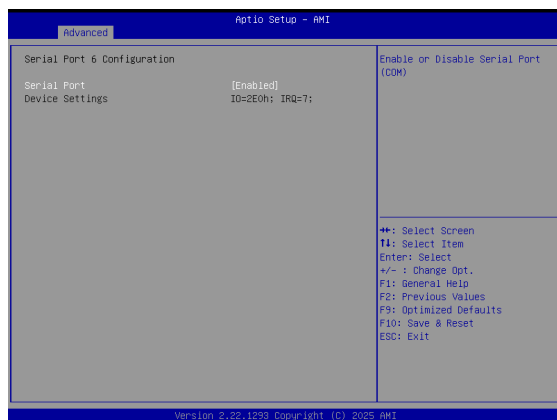
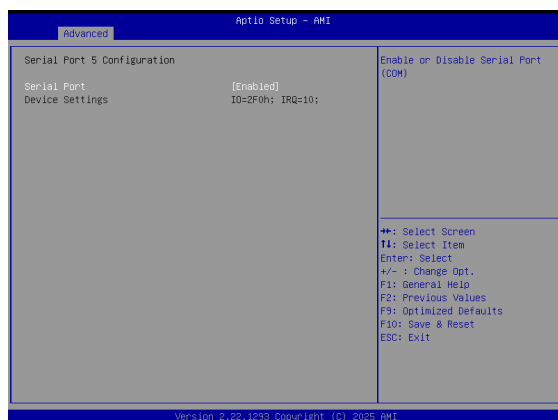

Serial Port

Enable or disable serial port.

▶ Advanced

IT8786 HW Monitor

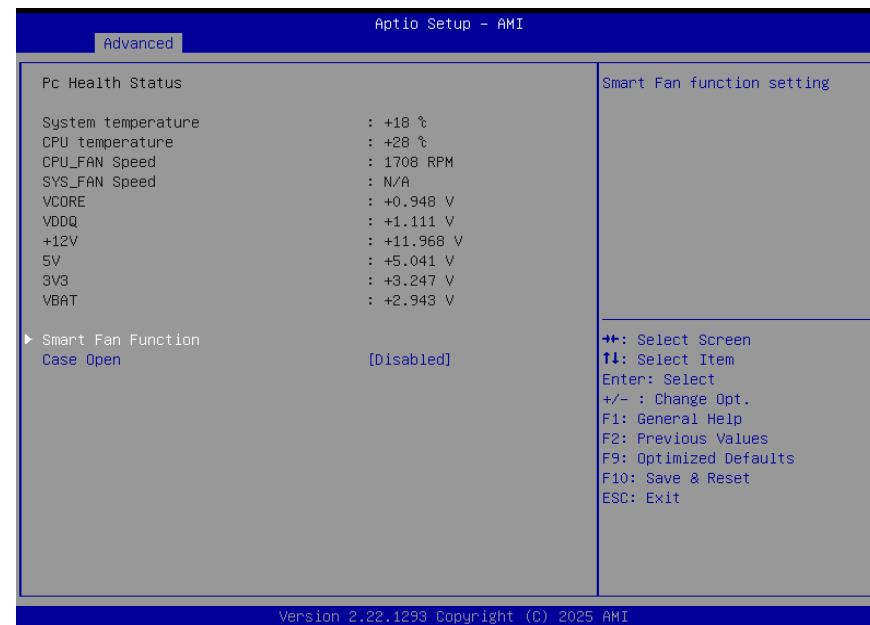

This section displays the system's health information, i.e. voltage readings, CPU and system temperatures, and fan speed readings

Smart Fan Function

Smart Fan Function Setting.

Case Open

Enable or disable the case open detection function.

▶ Advanced

IT8786 HW Monitor ▶ Smart FAN Function

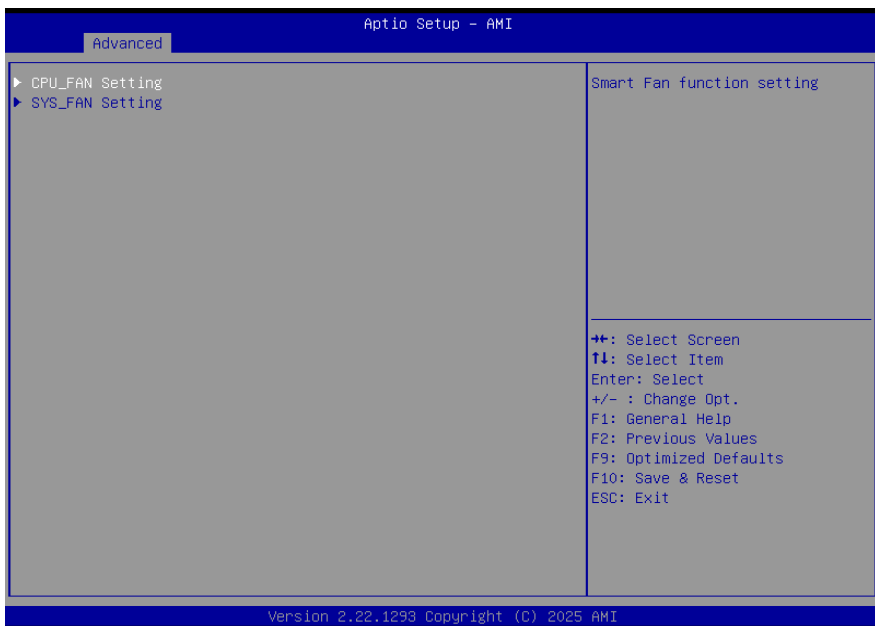

▶ Advanced

IT8786 HW Monitor ▶ Smart FAN Function ▶ CPU FAN Setting

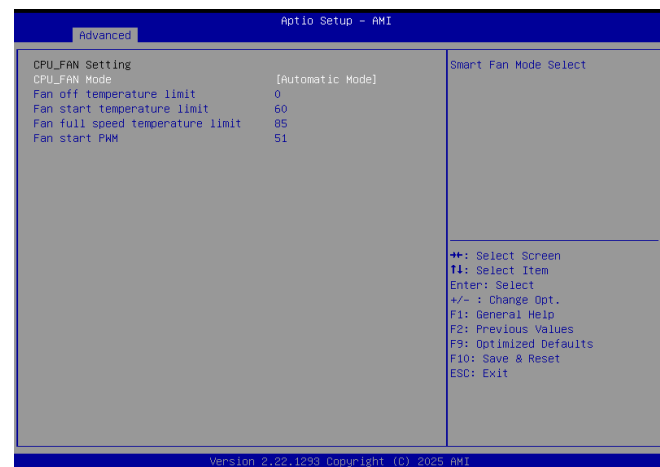

IT8786 HW Monitor ▶ Smart FAN Function ▶ SYS_FAN Setting



CPU Fan/SYS_FAN/SYS_FAN2/3 Mode

Smart Fan Mode Select

Fan off temperature limit

Fan will be turned off when the temperature is lower than this limit.

Fan start temperature limit

Fan will start working when the temperature is higher than this limit.

Fan full speed temperature limit

Fan will be full speed when the temperature is higher than this limit.

Fan start PWM

Fan will start with this PWM value.

▶ Advanced

Serial Port Console Redirection

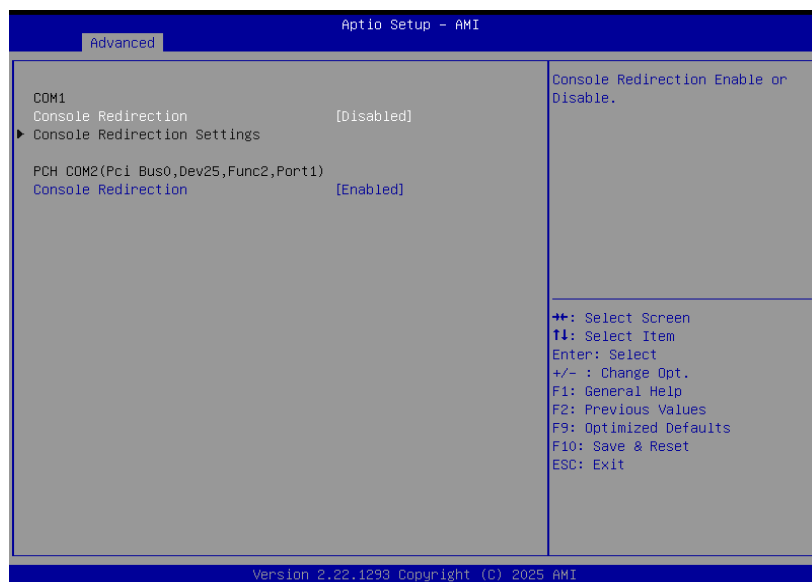

Console Redirection

By enabling Console Redirection of a COM port, the sub-menu of console redirection settings will become available for configuration as detailed in the following.

▶ Advanced

Serial Port Console Redirection ▶ Console Redirection Settings



Configure the serial settings of the current COM port.

Terminal Type

Select terminal type: VT100, VT100+, VT-UTF8 or ANSI.

Bits per second

Select serial port transmission speed: 9600, 19200, 38400, 57600 or 115200.

Data Bits

Select data bits: 7 bits or 8 bits.

Parity

Select parity bits: None, Even, Odd, Mark or Space.

Stop Bits

Select stop bits: 1 bit or 2 bits.

Flow Control

Select flow control type: None or Hardware RTS/CTS. Flow Control is for RS485 mode and is only supported by Serial Port 1 (COM1).

VT-UTF8 Combo Key Support

Enable VT-UTF8 Combination Key Support for ANSI/VT100 terminals.

Recorder Mode

With this mode enabled only text will be sent. This is to capture Terminal data.

Resolution 100x31

Enables or disables extended terminal resolution

Putty KeyPad

Select FunctionKey and KeyPad on Putty.

▶ Advanced

ACPI Settings



Wake system from S5 via RTC

When Enabled, the system will automatically power up at a designated time every day. Once it's switched to [Enabled], please set up the time of day — hour, minute, and second — for the system to wake up.

State After G3

Select between S0 State, and S5 State. This field is used to specify what state the system is set to return to when power is re-applied after a power failure (G3 state).

- **S0 State** The system automatically powers on after power failure.
- **S5 State** The system enter soft-off state after power failure. Power-on signal input is required to power up the system.

▶ Advanced

Network Stack Configuration

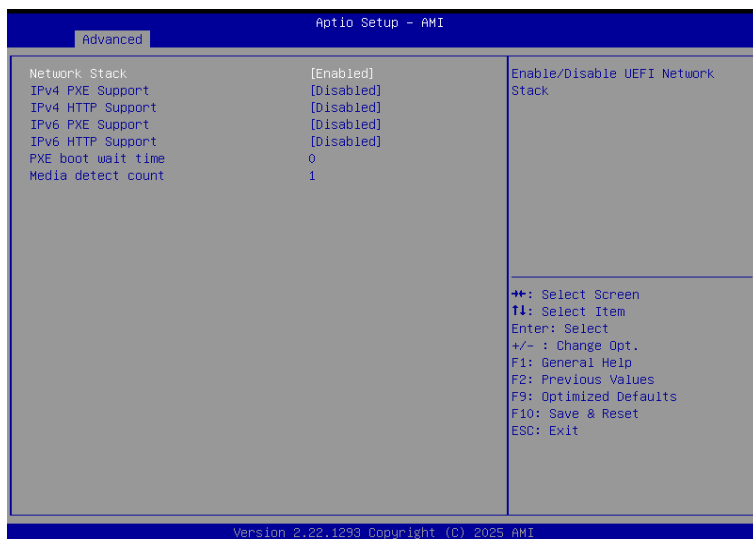

Network Stack

Enable or disable UEFI network stack. The following fields will appear when this field is enabled.

IPv4 PXE Support

Enable or disable IPv4 PXE boot support. If disabled, IPv4 PXE boot support will not be available.

IPv4 HTTP Support

Enable or disable IPv4 HTTP boot support. If disabled, IPv4 HTTP boot support will not be available.

IPv6 PXE Support

Enable or disable IPv6 PXE boot support. If disabled, IPv6 PXE boot support will not be available.

IPv6 HTTP Support

Enable or disable IPv6 HTTP boot support. If disabled, IPv6 HTTP boot support will not be available.

PXE boot wait time

Set the wait time in seconds to press ESC key to abort the PXE boot. Use either +/- or numeric keys to set the value.

Media detect count

Set the number of times the presence of media will be checked. Use either +/- or numeric keys to set the value.

▶ Advanced

NVMe Configuration

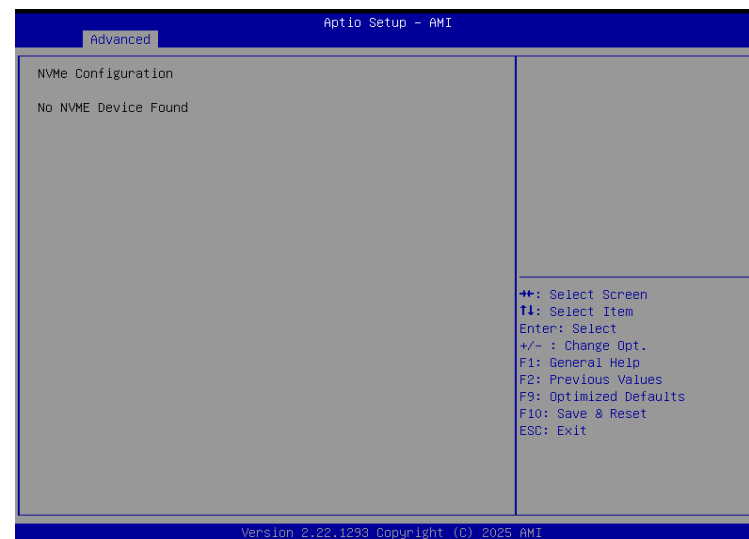

▶ Advanced

DFI WDT Configuration

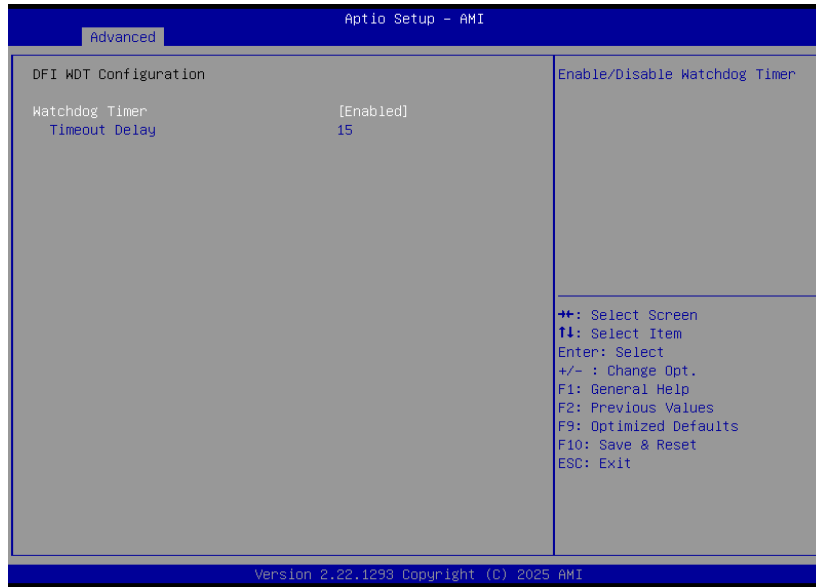

Watchdog Timer

Enable or disable Watchdog Timer.

▶ Advanced

USB Power Control

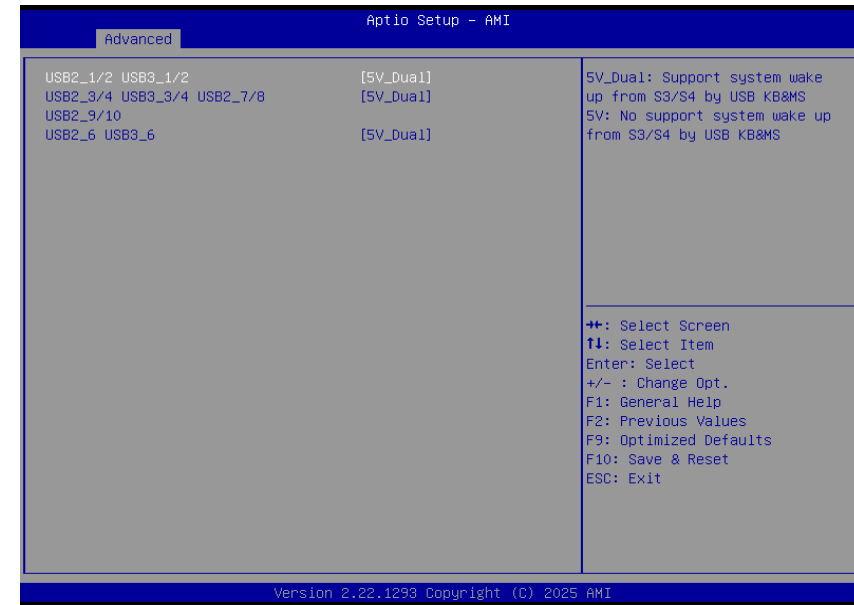

Server CA Configuration

5_Dual: Support system wake up from S3/S4 by USB KB&MS

5V: No support system wake up from S3/S4 by USB KB&MS

► **Advanced**

Tls Auth Configuration

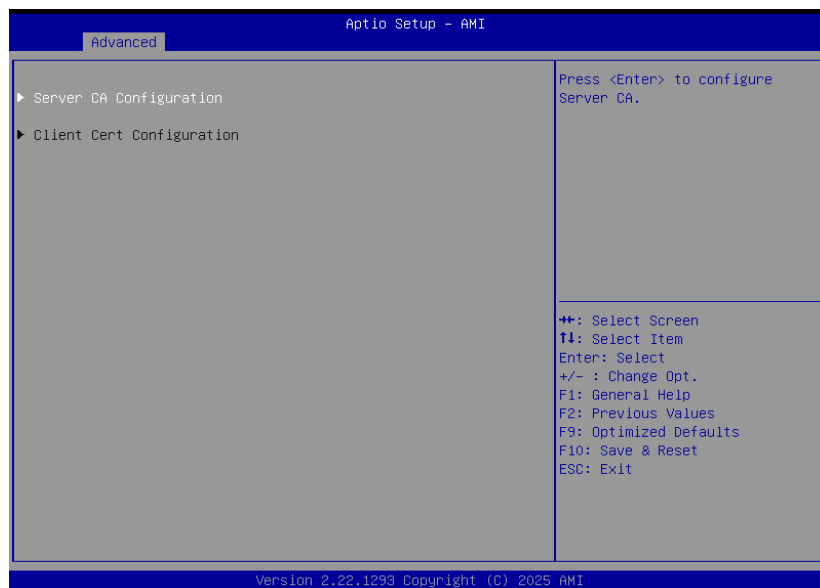

Server CA Configuration

Press <Enter> to configure Server CA.

► Chipset



Please select a submenu and press Enter. The submenus are detailed in the following pages.

► Chipset

System Agent (SA) Configuration

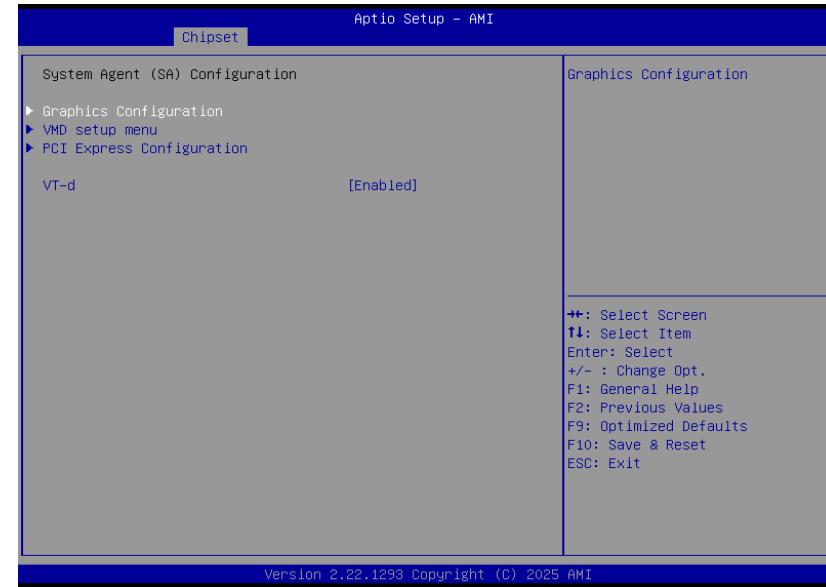

Graphics Configuration

Settings about graphic.

VMD setup menu

VMD Configuration Settings

PCI Express Configuration :

VT-d

VT-d capability.

▶ Chipset

PCH-IO Configuration



PCI Express Configuration

PCI Express Configuration Settings

SATA Configuration

SATA Device Options Settings

HD Audio Configuration

HD Audio Subsystem Configuration Settings

▶ Chipset

PCH-IO Configuration ▶ PCI Express Configuration

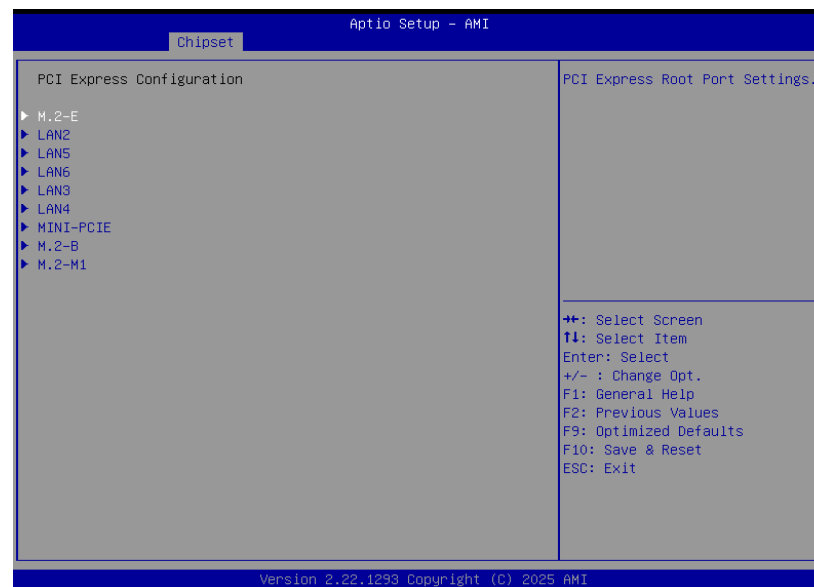

Select one of the PCI Express channels and press enter to configure the following settings.

M.2-E, LAN2, 3, 4, 5, 6, M.2-B, M.2-M1, MINI-PCIE

Control the PCI Express Root Port.

► Chipset

PCH-IO Configuration ► SATA Configuration

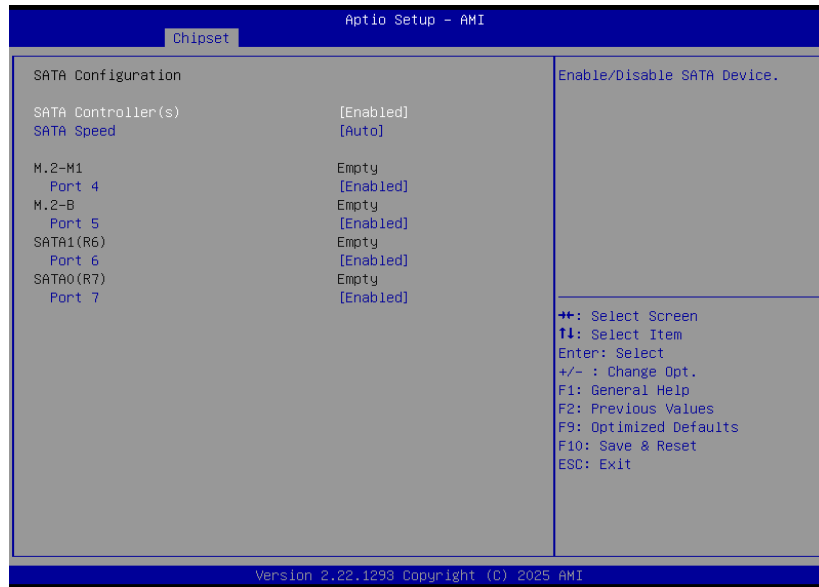

SATA Controller(s)

This field is used to enable or disable the Serial ATA controller.

SATA Speed

This field is used to select SATA speed generation limit: Auto, Gen1, Gen2 or Gen3.

Ports

Enable or disable the Serial ATA port and its hot plug function.

► Chipset

PCH-IO Configuration ► HD Audio Configuration



HD Audio

Control the detection of the HD Audio device.

- **Disabled** HDA will be unconditionally disabled.
- **Enabled** HDA will be unconditionally enabled.

► Security

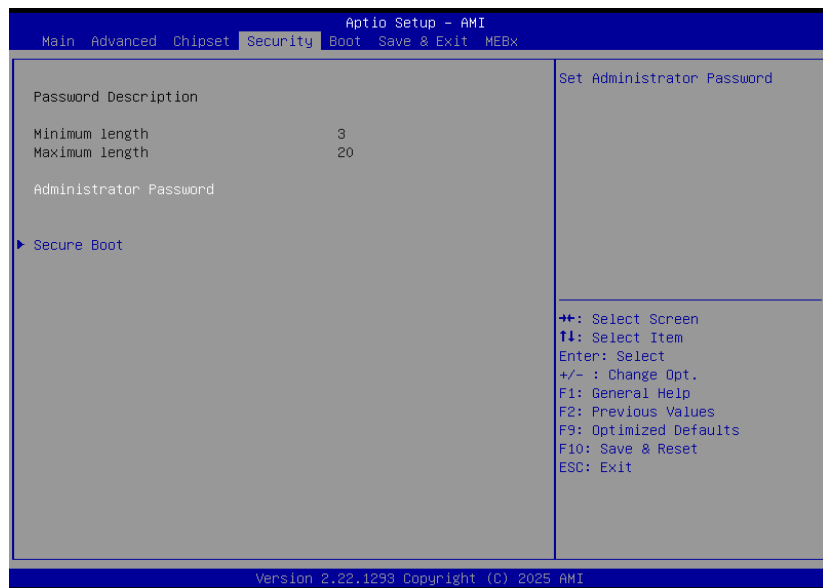

Administrator Password

Set the administrator password. To clear the password, input nothing and press enter when a new password is asked. Administrator Password will be required when entering the BIOS.

► Security

Secure Boot



Secure Boot

The Secure Boot store a database of certificates in the firmware and only allows the OSEs with authorized signatures to boot on the system. To activate Secure Boot, please make sure that "Secure Boot" is "[Enabled]", Platform Key (PK) is enrolled, "System Mode" is "User", and CSM is disabled. After enabling/disabling Secure Boot, please save the configuration and restart the system. When configured and activated correctly, the Secure Boot status will be "Active".

Secure Boot Mode

Select the secure boot mode – Standard or Custom. When set to Custom, the following fields will be configurable for the user to manually modify the key database.

Restore Factory Keys

Force system to User Mode. Load OEM-defined factory defaults of keys and databases onto the Secure Boot. Press Enter and a prompt will show up for you to confirm.

Reset To Setup Mode

Clear the database from the NVRAM, including all the keys and signatures installed in the Key Management menu. Press Enter and a prompt will show up for you to confirm.

Key Management

Enables expert users to modify Secure Boot Policy variables without full authentication.

► Boot

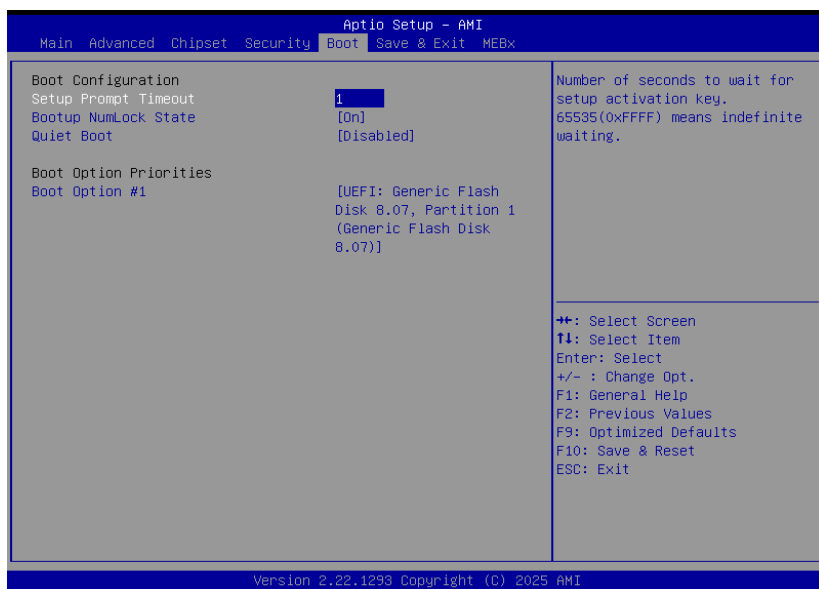

Setup Prompt Timeout

Set the number of seconds to wait for the setup activation key. 65535 (0xFFFF) denotes indefinite waiting.

Bootup NumLock State

Select the keyboard NumLock state: On or Off.

Quiet Boot

This section is used to enable or disable quiet boot option.

Boot Option Priorities

Rearrange the system boot order of available boot devices.

► Save & Exit

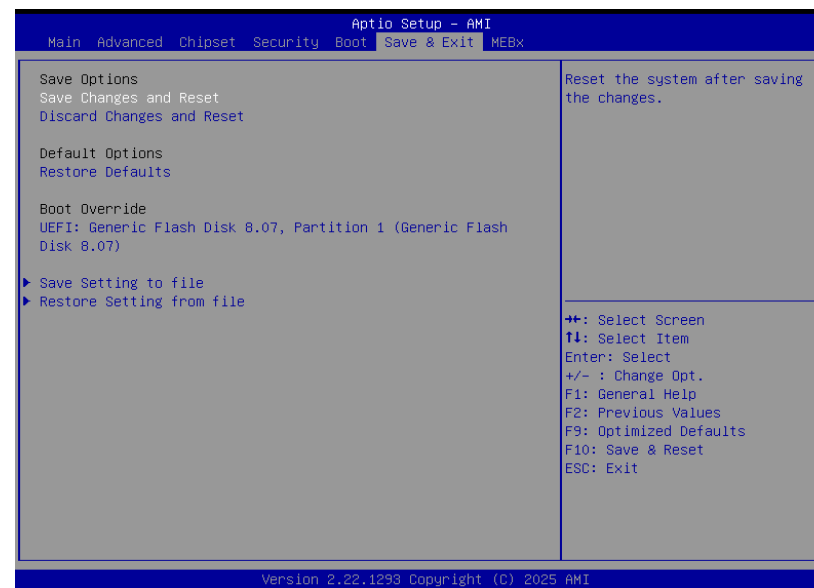

Save Changes and Reset

To save the changes, select this field and then press <Enter>. A dialog box will appear. Select Yes to reset the system after saving all changes made.

Discard Changes and Reset

To discard the changes, select this field and then press <Enter>. A dialog box will appear. Select Yes to reset the system setup without saving any changes.

Restore Defaults

To restore and load the optimized default values, select this field and then press <Enter>. A dialog box will appear. Select Yes to restore the default values of all the setup options.

Boot Override

Move the cursor to an available boot device and press Enter, and then the system will immediately boot from the selected boot device. The Boot Override function will only be effective for the current boot. The "Boot Option Priorities" configured in the Boot menu will not be changed.

- **Save Setting to file** Select this option to save BIOS configuration settings to a USB flash device.
- **Restore Setting from file** This field will appear only when a USB flash device is detected. Select this field to restore setting from the USB flash device.

► MEBx

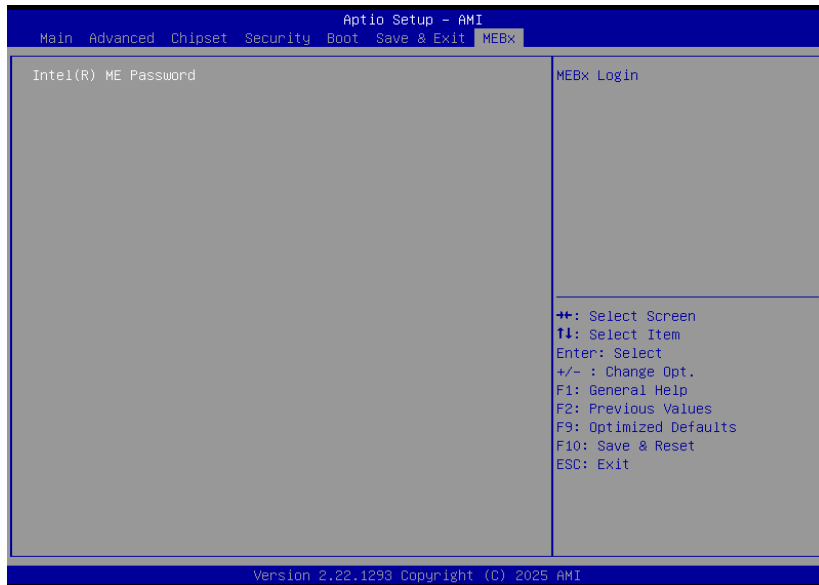

► Updating the BIOS

To update the BIOS, you will need the new BIOS file and a flash utility. Please contact technical support or your sales representative for the files and specific instructions about how to update BIOS with the flash utility.

► Notice: BIOS SPI ROM

1. The Intel® Management Engine has already been integrated into this system board. Due to the safety concerns, the BIOS (SPI ROM) chip cannot be removed from this system board and used on another system board of the same model.
2. The BIOS (SPI ROM) on this system board must be the original equipment from the factory and cannot be used to replace one which has been utilized on other system boards.
3. If you do not follow the methods above, the Intel® Management Engine will not be updated and will cease to be effective.



Note:

- a. You can take advantage of flash tools to update the default configuration of the BIOS (SPI ROM) to the latest version anytime.
- b. When the BIOS IC needs to be replaced, you have to populate it properly onto the system board after the EEPROM programmer has been burned and follow the technical person's instructions to confirm that the MAC address should be burned or not.
- c. After updating unique MAC Address from manufacturing, NVM will be protected immediately after power cycle. Users cannot update NVM or MAC address.