



DFI

GHF51 Creates More Value in Facial Recognition Applications

DFI's GHF51 is the world's first 1.8" industrial motherboard powered by high-performance AMD Ryzen™ R1000 Processors; holding unprecedented processing throughput despite its smaller size. It ascends from the industrial Pi and defines a new level of balance between performance and cost-effectiveness. Its flexible expandability brings versatility that is perfect for industrial application development, edge computing, AI vision, and more. The ubiquitous facial recognition is an obvious common application.

Application: Facial recognition

Solution: GHF51

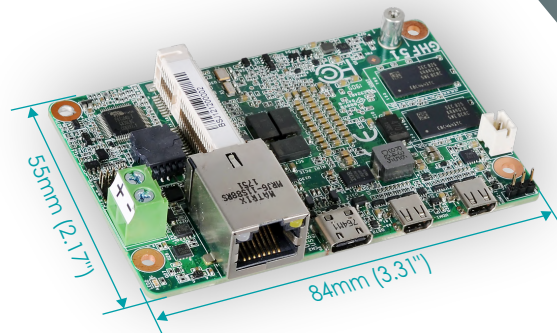

In recent years, with the development of high-performance low-power x86 processors, there have been more appealing miniaturized personal computers from NUC to compute stick (Stick PC), which has become a trend and has also attracted the attention of everyone. What's more, there is no shortage of applications that introduce it into the field of industrial control, such as facial recognition systems. However, in addition to the limited size of such products and the inability to provide a complete I/O interface, if the product line is discontinued, customers will also face the risk of being out of stock.

A Fortune 500 company used Intel Compute Stick personal computers to connect to video cameras via USB to build a facial recognition system. The last generation of its products has been the product of the first quarter of 2016, and even it became EOL (End Of Life) in June 2020. Therefore,

The customer had to look for Single Board Computer (SBC) as an alternative, but faced the following problems:

- | Due to existing mechanical limitations, the size cannot exceed 2.5 inches, and low power consumption is also required.
- | Must support the I/O interface used in the previous solution, such as HDMI, USB 3.0, and TPM 2.0.
- | Almost all the similar products that can be found on the market use relatively low-end Intel Atom processors, but their performance cannot meet the needs of existing facial recognition software, and the memory capacity is also insufficient.
- | Strict budget restrictions due to the need to purchase additional Microsoft Windows 10 licenses.

Finally, The customer chose DFI's GHF51 as a solution to replace Intel Compute Stick.

I/O interface of DFI GHF51

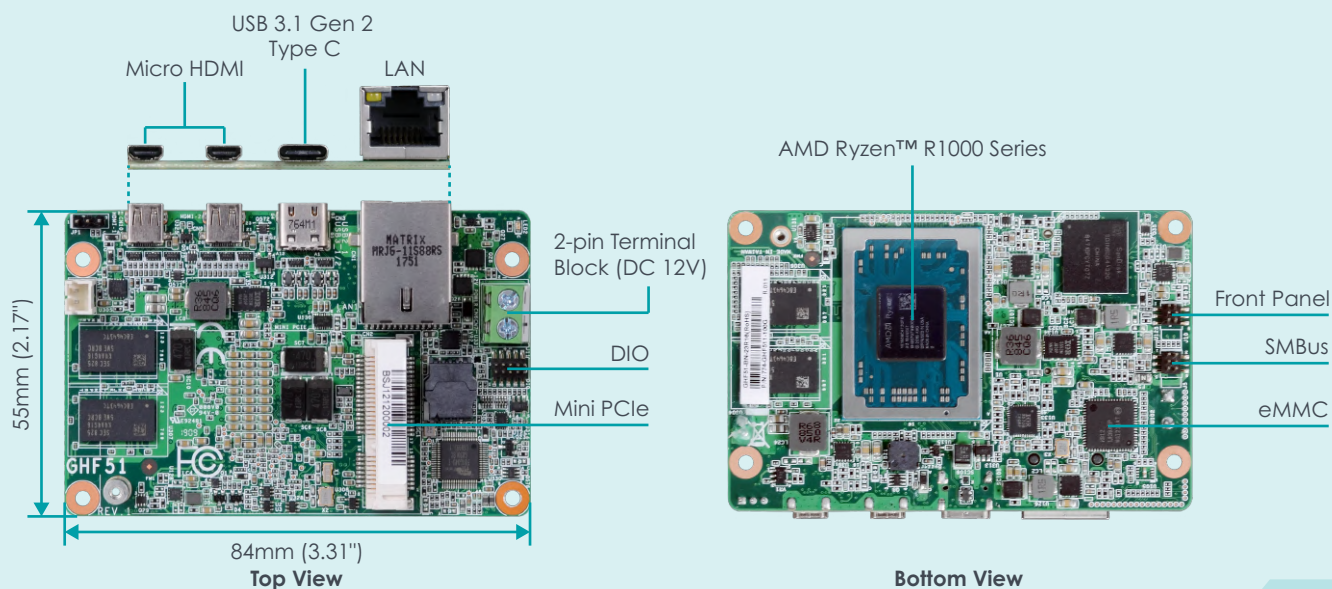

Reasons are listed as below:

- | Its form factor is small enough for space-limited applications.
- | It meets the basic specifications with Micro HDMI, USB 3.1, and TPM 2.0 (firmware TPM).
- | AMD Ryzen™ Embedded R1505G has two Zen processor cores and an integrated Vega 3 graphic engine with a clock frequency of up to 3.3GHz, which is enough to provide the same performance as Intel® Core™ m3 or even close to the Intel® Core™ i series and equipped with sufficient 4GB DDR4 memory, brings the margin to introduce more advanced facial recognition algorithms in the future.
- | The unit price meets the budget range and there is no need to purchase additional peripheral hardware.

In addition to a perfect replacement for Intel Compute Stick, GHF51 brings additional value:

- | Compared with the discontinued Intel Compute Stick, GHF51 provides a ten-year product life span so there is no need to worry about being out-of-stock in the future.
- | GHF51 is industrial-graded. Its reliability, stability, durability, and resistance to harsh environments are beyond the reach of consumer-grade products.
- | Although the GHF51 occupies a very small space, it can still be expanded through the full-size Mini PCIe interface to install 3G/4G/5G/Wifi card to connect to the wireless network and provide a variety of I/O interface such as dual HDMI display, USB 3.1 interface, Gigabit Ethernet,

Evolution of the application architecture of facial recognition on customers.

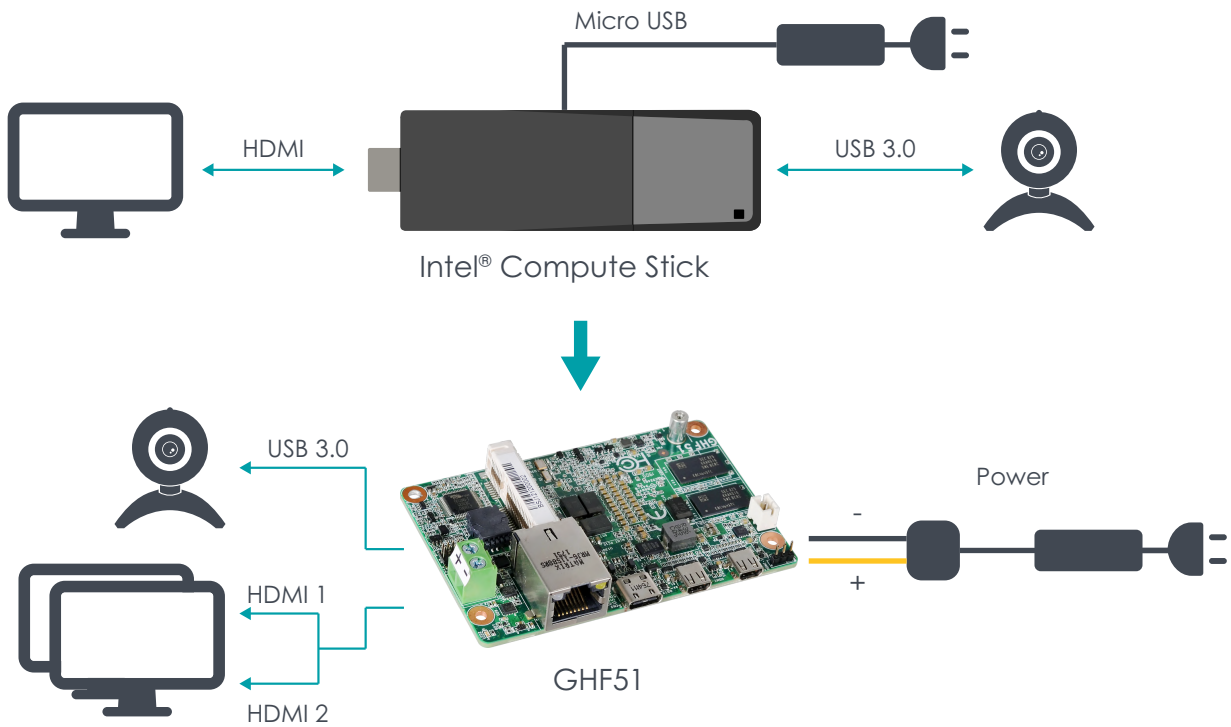

and Digital I/O that is not provided by ordinary personal computers. Its powerful flexibility and versatility can better meet future requirements, such as dual-screen systems, high-speed networking, and control systems connected with many peripheral devices through DIO Link, extending to access control or smart home system.

GHF51 can bring facial recognition solutions with more flexibility and lower cost.

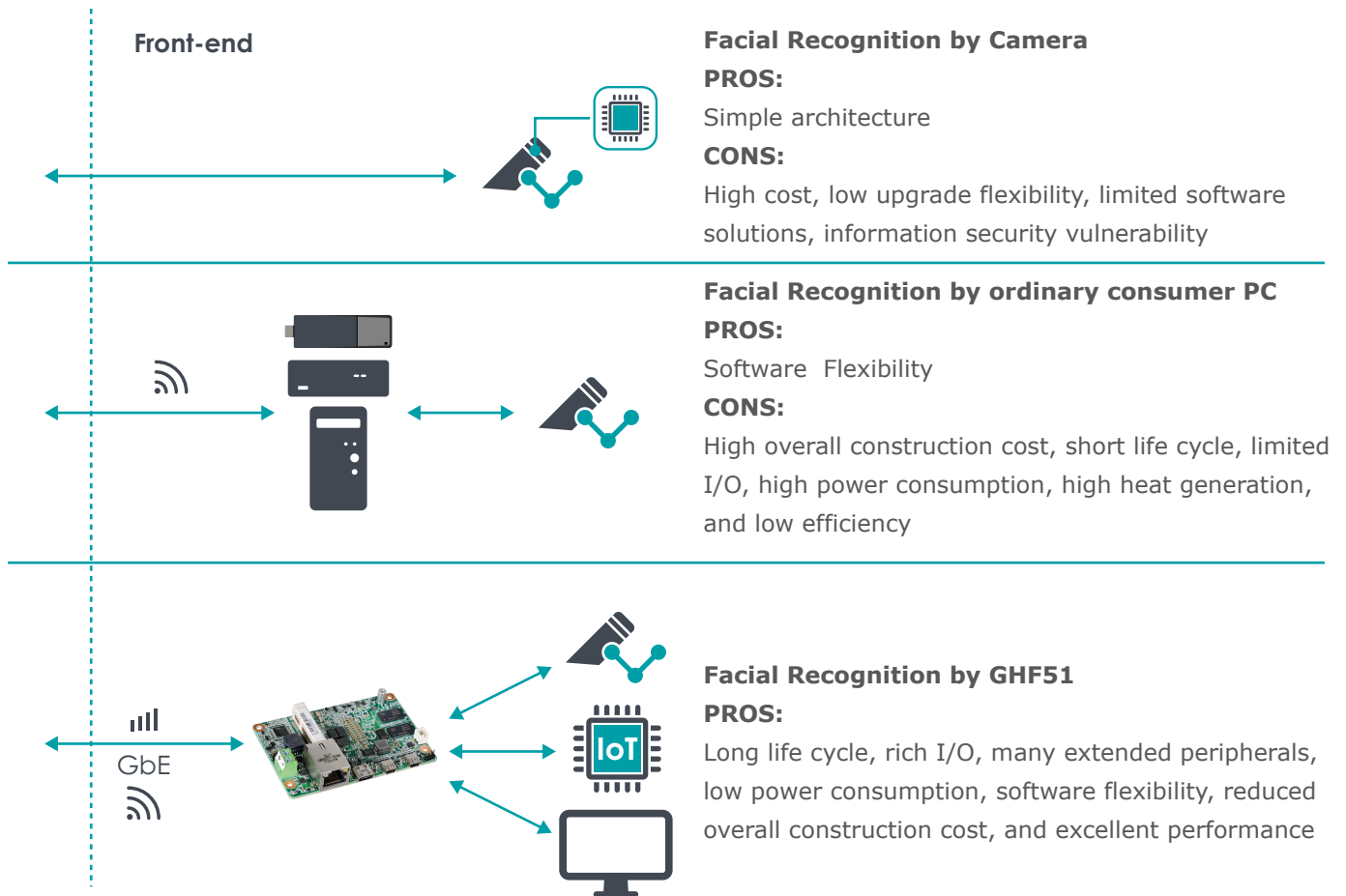

DFI's GHF51 is the world's first 1.8" industrial motherboard powered by high-performance AMD Ryzen™ R1000 Processors, holding unprecedented processing throughout despite its mini size. It ascends from the industrial Pi and defines a new level of balance between performance and cost-effectiveness. Its flexible expandability brings versatility that is perfect for industrial application development, edge computing, AI vision, and more. Focusing on industrial solutions, DFI followed AMD's long-lifecycle support roadmap for CPU provides product availability for up to 10 years. This support promises system upgrades in a long term without concern for compatibility.

Please click or scan the QR code to fill out an inquiry form if you would like us to contact you.



DFI

Founded in 1981, DFI is a global leading provider of high-performance computing technology across multiple embedded industries. With its innovative design and premium quality management system, DFI's industrial-grade solutions enable customers to optimize their equipment and ensure high reliability, long-term life cycle, and 24/7 durability in a breadth of markets including factory automation, medical, gaming, transportation, smart energy, defense, and intelligent retail.

Website: www.dfi.com

eStore: estore.dfi.com



Copyright © 2020 DFI Inc. All rights reserved. DFI is a registered trademark of DFI Inc. All other trademarks are the property of their respective owners.

For more information, please contact your DFI regional sales representative or send us an email: inquiry@dfi.com